

Touchstone24

F X Type: **MODULATION**

Build Level: Intermediate

Based On: EHX® Small Clone™

Last Updated: August 17, 2024 5:53 PM

© 2024 [madbeanpedals](#)



The 2024 version of the **Touchstone** has no circuit changes and minor layout tweaks.

Overview

It's warm. It's lush. It's a classic! The Touchstone is based around the big box MN3007 Small Clone. A little less complicated than the venerated CE-2 but a righteous chorus all on its own. Capable of dense slow chorus tones while the large depth range can take you well into seasick territory. If you've never built/played a Small Clone you will not be disappointed.

Controls

- **RATE, DEPTH:** Min to max in both controls.
- **T1:** This trimmer sets the bias for the input of the MN3007.

This link has some interesting info and history on the Small Clone:

<https://www.ehx.com/forums/viewthread/5555>

Terms of Use: You are free to use purchased **Touchstone24** circuit boards for both DIY and small commercial operations. You may not offer **Touchstone24** PCBs for resale or as part of a "kit" in a commercial fashion. Peer to peer re-sale is fine, though.

Technical assistance for is available via the [madbeanpedals forum](#). Please go there rather than emailing me for personal assistance. This is because (1) I'm not always available to respond via email in a timely and continuous manner, and (2) posting technical problems and solutions in the forum creates a record from which other members may benefit.

All copyrights and registered trademarks are property of their original owners. Any mention of trademarked or intellectual properties in this documents is purely for comparative purposes.

Parts Layout

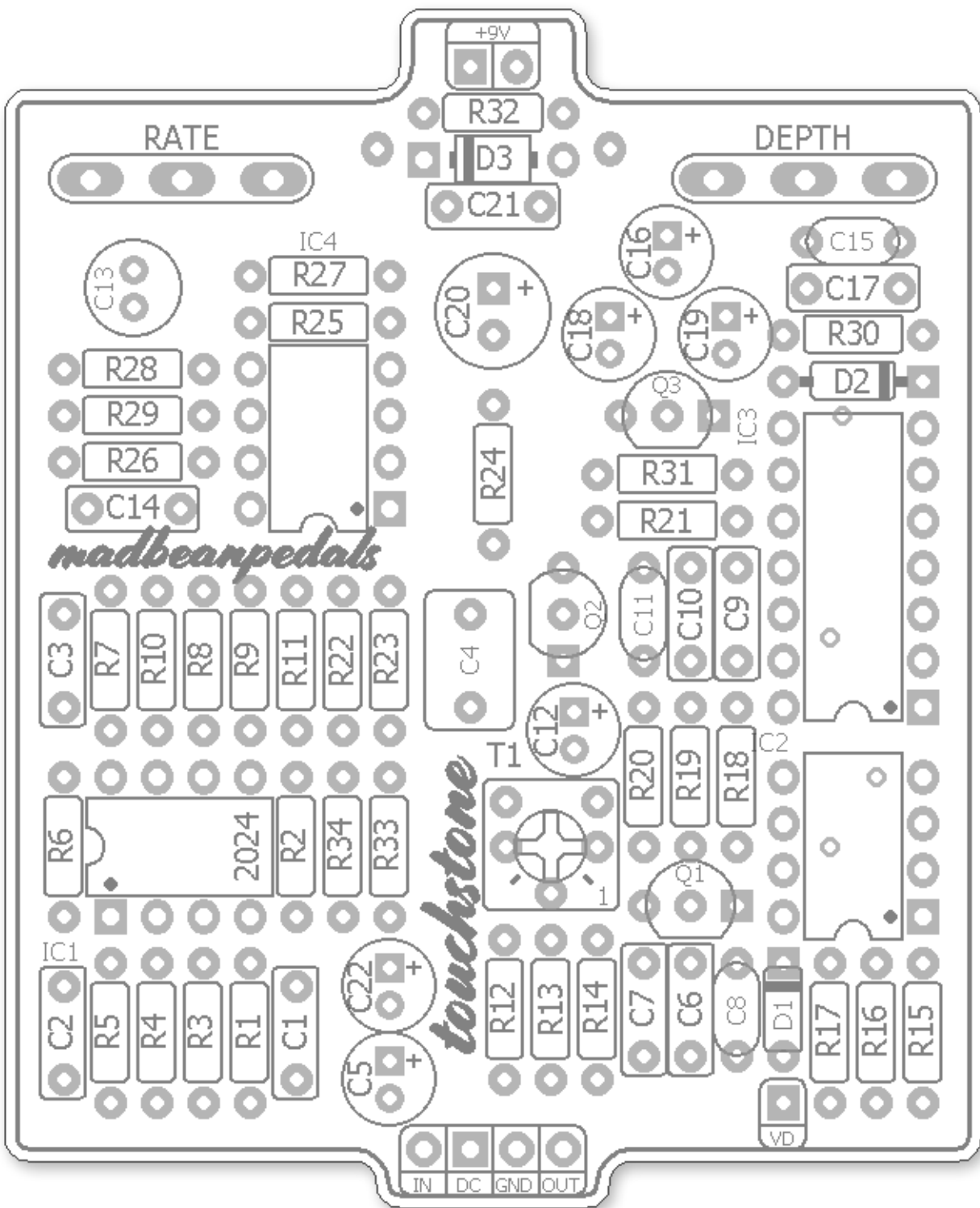

Component Values

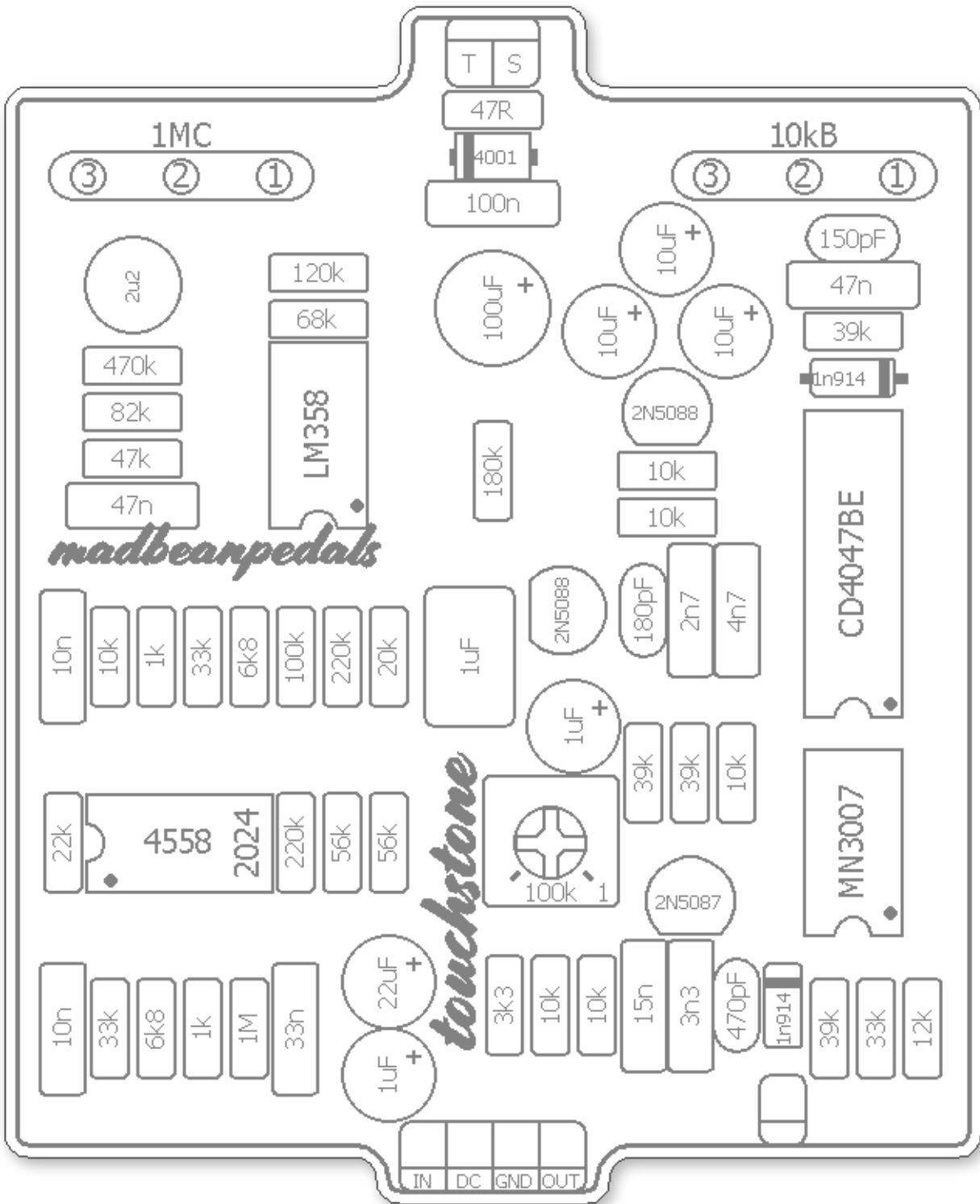

Trace Layout

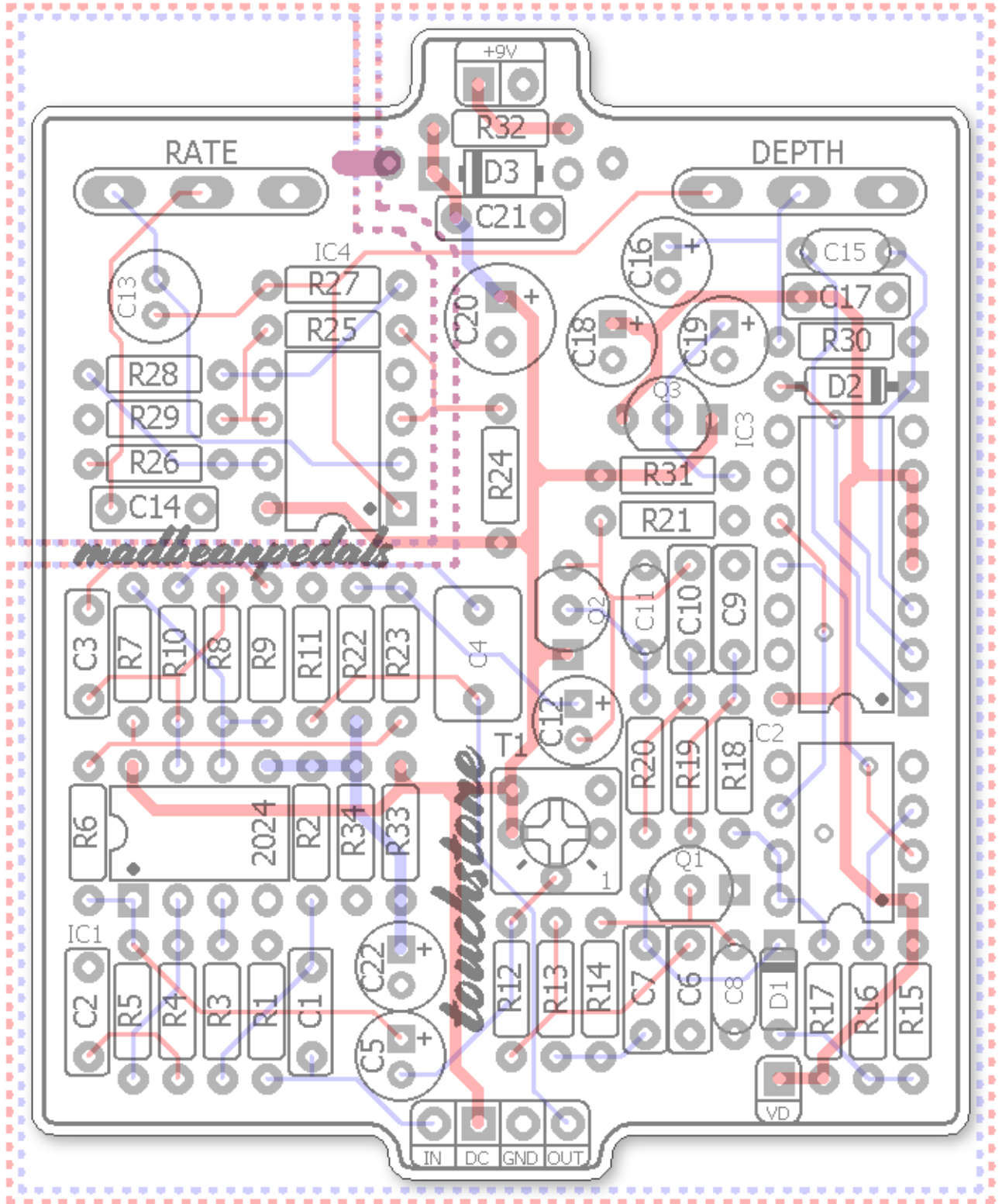

Wiring

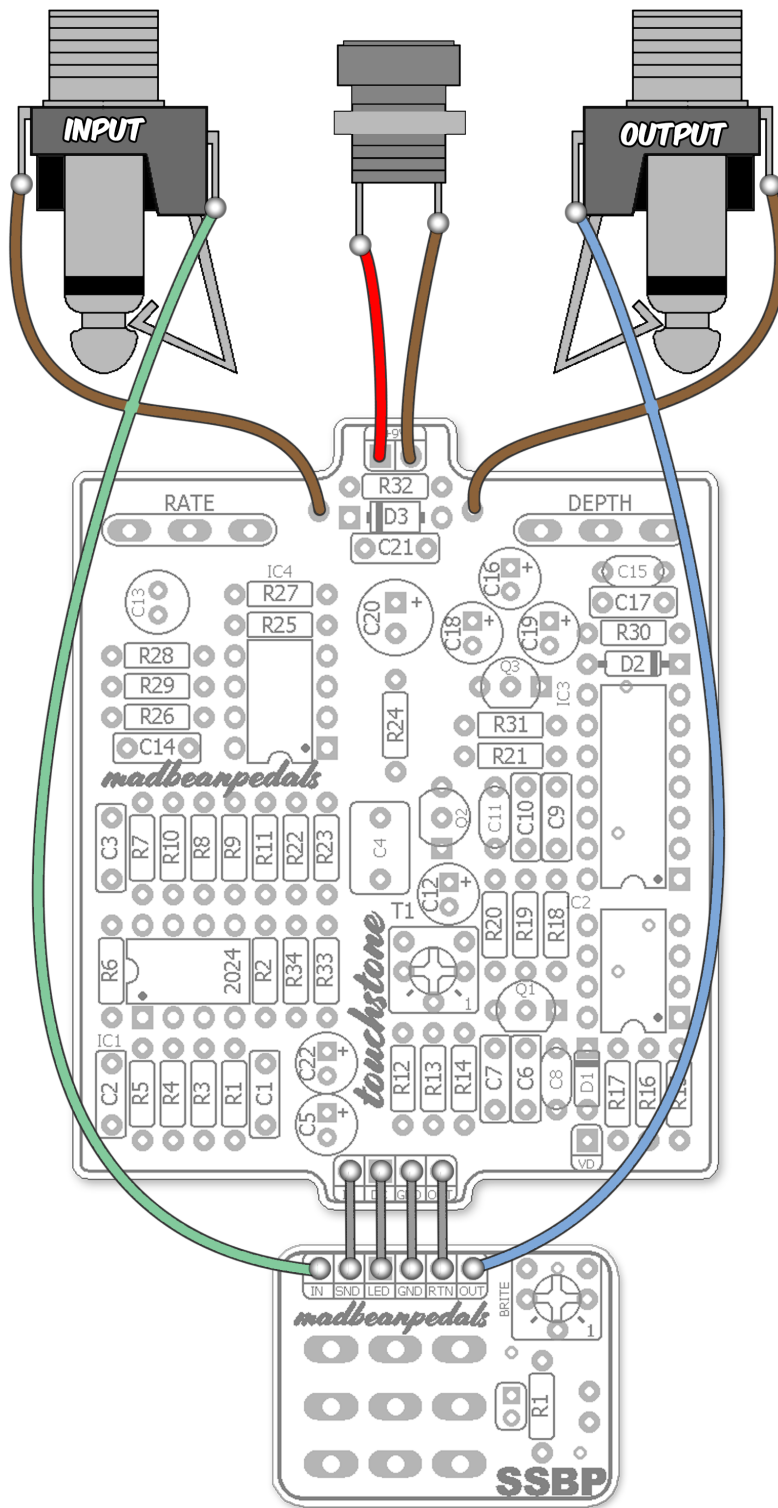

The Touchstone24 is compatible with both the **SSBP** and **SSABP** bypass boards available at madbeanpedals. The wiring is the same for both.

B.O.M.

Resistors		Resistors		Caps		Diodes	
R1	1M	R23	20k	C1	33n	D1	1n914
R2	220k	R24	180k	C2	10n	D2	1n914
R3	1k	R25	68k	C3	10n	D3	1N4001
R4	6k8	R26	47k	C4	1uF	Transistors	
R5	33k	R27	120k	C5	1uF	Q1	2N5087
R6	22k	R28	470k	C6	3n3	Q2	2N5088
R7	10k	R29	82k	C7	15n	Q3	2N5088
R8	33k	R30	39k	C8	470pF	ICs	
R9	6k8	R31	10k	C9	4n7	IC1	4558
R10	1k	R32	47R	C10	2n7	IC2	MN3007
R11	100k	R33	56k	C11	180pF	IC3	CD4047BE
R12	3k3	R34	56k	C12	1uF	IC4	LM358
R13	10k			C13	2u2	Trimmer	
R14	10k			C14	47n	T1	100k
R15	12k			C15	150pF	Pots	
R16	33k			C16	10uF	DEPTH	10kB
R17	39k			C17	47n	RATE	1MC
R18	10k			C18	10uF		
R19	39k			C19	10uF		
R20	39k			C20	100uF		
R21	10k			C21	100n		
R22	220k			C22	22uF		

Shopping List

Value	QTY	Type	Rating	Value	QTY	Type	Rating
47R	1	Metal / Carbon Film	1/4 W	1uF	2	Electrolytic	16v min.
1k	2	Metal / Carbon Film	1/4 W	10uF	3	Electrolytic	16v min.
3k3	1	Metal / Carbon Film	1/4 W	22uF	1	Electrolytic	16v min.
6k8	2	Metal / Carbon Film	1/4 W	100uF	1	Electrolytic	16v min.
10k	6	Metal / Carbon Film	1/4 W	2u2	1	Bi-Polar	16v min.
12k	1	Metal / Carbon Film	1/4 W	1n914	2		
20k	1	Metal / Carbon Film	1/4 W	1N4001	1		
22k	1	Metal / Carbon Film	1/4 W	2N5087	1		
33k	3	Metal / Carbon Film	1/4 W	2N5088	2		
39k	4	Metal / Carbon Film	1/4 W	4558	1		
47k	1	Metal / Carbon Film	1/4 W	MN3007	1		
56k	2	Metal / Carbon Film	1/4 W	CD4047BE	1		
68k	1	Metal / Carbon Film	1/4 W	LM358	1		
82k	1	Metal / Carbon Film	1/4 W	100k	1	Bourns 3362p or 6mm	
100k	1	Metal / Carbon Film	1/4 W	10kB	1	PCB Mount, Right Angle	16mm
120k	1	Metal / Carbon Film	1/4 W	1MC	1	PCB Mount, Right Angle	16mm
180k	1	Metal / Carbon Film	1/4 W				
220k	2	Metal / Carbon Film	1/4 W				
470k	1	Metal / Carbon Film	1/4 W				
1M	1	Metal / Carbon Film	1/4 W				
150pF	1	Ceramic / MLCC	16v min.				
180pF	1	Ceramic / MLCC	16v min.				
470pF	1	Ceramic / MLCC	16v min.				
2n7	1	Film	16v min.				
3n3	1	Film	16v min.				
4n7	1	Film	16v min.				
10n	2	Film	16v min.				
15n	1	Film	16v min.				
33n	1	Film	16v min.				
47n	2	Film	16v min.				
100n	1	Film	16v min.				
1uF	1	Film	16v min.				

Additional Hardware

- (1) 125B enclosure
- (2) 1/4" mono jacks
- (1) Slim 2.1mm DC jack
- (1) Standard 3PDT footswitch
- (1) 5mm LED

Build Notes

Biasing the effect

- An audio probe is helpful but not required. If you do have an audio probe, simply set both knobs in the middle position, probe either pin 7 or 8 of the MN3007 and adjust T1 until you hear the modulated signal coming through. Make fine adjustments until you reach the optimal position on the trimmer. If you don't have an audio probe, just follow the same process while listening to the actual circuit output instead of the MN3007. The optimal setting is the one that gives you the cleanest and most "chorusey" output.

Additional Notes

- R23 sets the mix of the chorus effect. You can make the modulated signal louder by adjusting this resistor down in value. However, it's a really good mix with the default 20k.
- The Touchstone is meant for 9v operation but it will run on 15v regulated without any component adjustments. I'm not sure there is a lot of difference based on my own listening test but it is an option. The 15v must be regulated though so you would need to incorporate a charge pump circuit with regulator to do so.
- You should be able to adjust the fastest speed possible by lowering R26 (not tested). Doing so will shorten the max slow speed, as well.
- C13 is a Bi-Polar cap. Be sure to use the correct part here.

MN3007:

<https://smallbear-electronics.mybigcommerce.com/ic-mn3007-audio-bbd-dip-8-xvive/>

<https://smallbear-electronics.mybigcommerce.com/ic-mn3007-bbd/>

<https://synthcube.com/cart/mn3007-xvive-audio?search=mn3007&description=true>

<https://cabintechglobal.com/mn3007> - CHEAPER PRICE!

Circuit Voltages

IC1	4558	IC2	MN3007	IC3	4047	IC4	LM358	Q1	2N5087
1	4.57	1	8.49	1	8.33	1	varies	C	0
2	4.57	2	4.2	2	~80mV	2	4.12	B	2.97
3	4.45	3	4.1	3	~7.4	3	4.08	E	3.57
4	0	4	0	4	8.49	4	0	Q2	2N5088
5	4.55	5	0	5	8.49	5	varies	C	9.13
6	4.57	6	4.2	6	8.49	6	2.23	B	3.9
7	4.56	7	3.99	7	0	7	varies	E	3.37
8	9.12	8	3.99	8	0	8	9.13	Q3	2N5088
				9	0			C	9.13
				10	4.2			B	9.1
VD	8.49			11	4.2			E	8.49
VC	9.13			12	0				
VB	4.55			13	8.35				
				14	8.49				

- 9.42vDC One Spot
- Current Draw ~ 6mA
- The VD, VC and VB pads on the PCB are for reference only. You can use them to verify you have voltage on each of the supply rails, if you like.

Drill Template

Coordinates are denoted in **(X,Y)**, **drill size** format starting from the center **(0,0)** location of the enclosure.

Tayda drill template: https://drill.taydakits.com/box-designs/new?public_key=eDNzRDdtelpRYytab3hxbTU4MUhJdz09Cg==

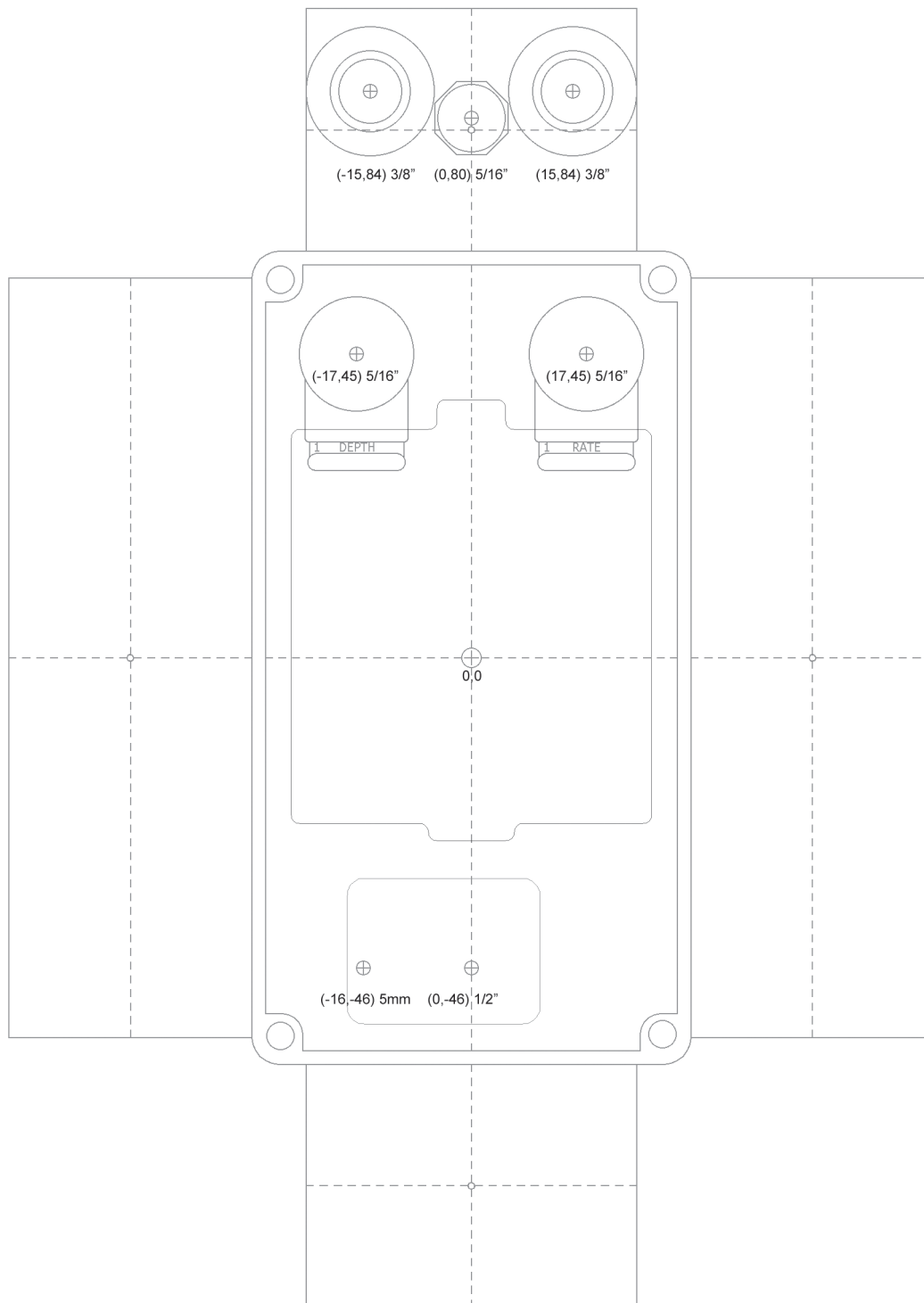

Hardware

125B enclosure
Mono jacks
Slim 2.1mm DC jack
Standard 3PDT footswitch
5mm LED

NOTE: Different 1/4" and DC jack styles may require different sized drill holes.

Build Pic

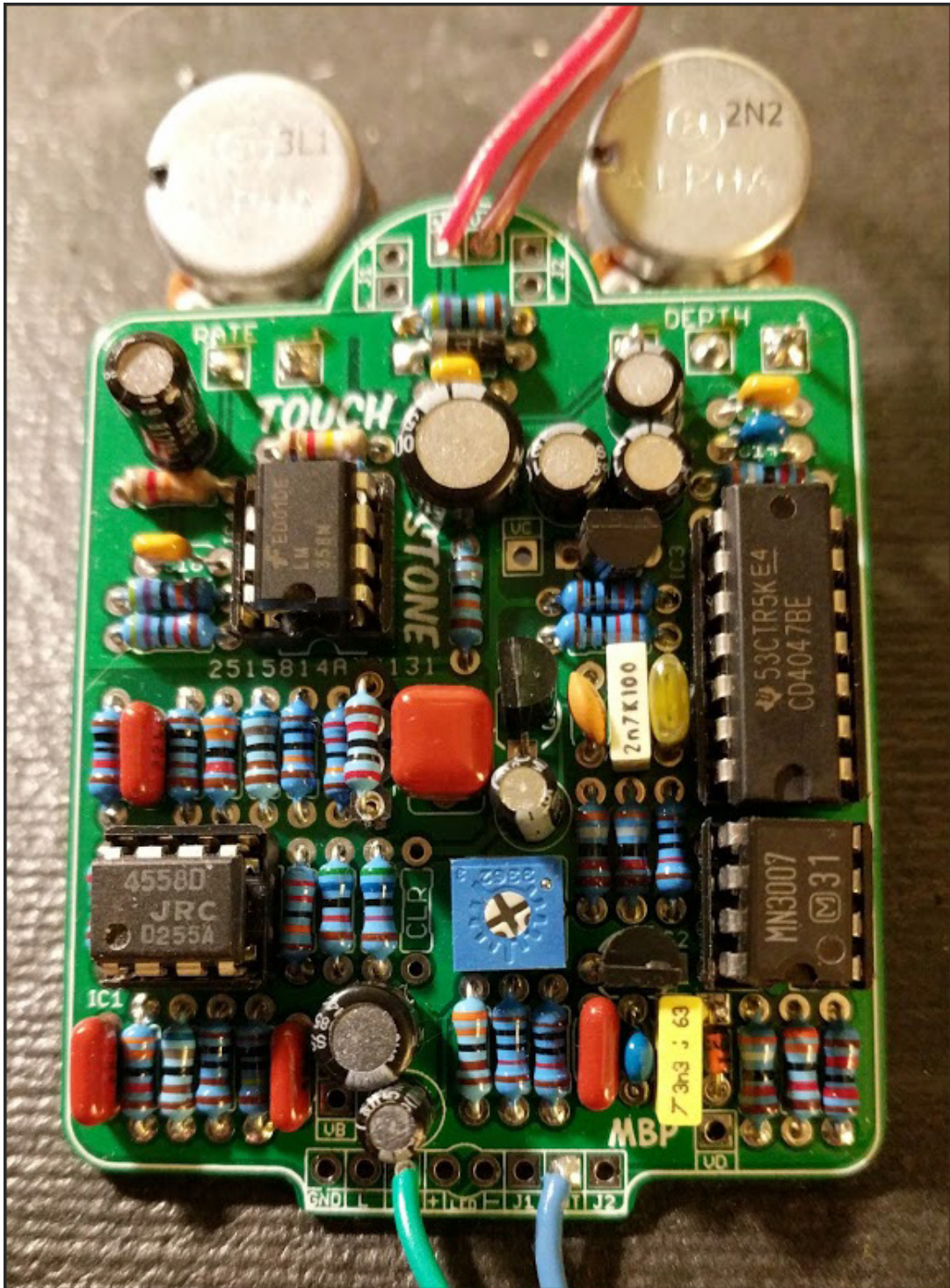

Previous version build

Schematic

