

StageFright24

FX Type: **MODULATION**
Build Level: Intermediate
Based On: Maestro® MP-1™

Last Updated: July 18, 2024 12:29 PM

© 2024 [madbeanpedals](#)



Overview

The 2024 version of the Stage Fright has no circuit changes and minor layout adjustments. It now includes a bypass PCB with purchase.

The Stage Fright first showed up around 2013 and was revised in 2015. It was discontinued a few years after. But, people kept asking me about it and requesting more boards to be made. It seems I should have never stopped offering it based on the number of requests I've gotten in the last 3-4 years.

The core of the new version is the same basic circuit with minimal adjustments to the layout. I've removed the external LED speed indicator and the optional CV control (I think I saw maybe one person use this option over its initial five year lifespan). Other than that, it's the same. But NEW! AND BETTER! YES>>>BETTAH.

This is an excellent sounding phaser. The controls are simple and it's got a pretty wide sweep to boot. Note that the Stage Fright is not a clone of the Maestro Stage Phaser, but rather its precursor the MP-1. The Stage Phaser is different in its LFO as well as some other tweaks. I plan on tackling that one later on. For now, give the Stage Fright a go. It's got serious retro vibe!

Controls

- **SPEED:** Phaser LFO rate.
- **BALLS:** Sets the amount of phaser feedback.
- **STAGES:** Left position: stock MP-1 setting. Right position: adds an additional phase stage for a different tonality.
- **T1:** this trimmer sets the overall depth of the LFO. See Notes for further explanation.

Terms of Use: You are free to use purchased **StageFright24** circuit boards for both DIY and small commercial operations. You may not offer **StageFright24** PCBs for resale or as part of a "kit" in a commercial fashion. Peer to peer re-sale is fine, though.

Technical assistance for is available via the [madbeanpedals forum](#). Please go there rather than emailing me for personal assistance. This is because (1) I'm not always available to respond via email in a timely and continuous manner, and (2) posting technical problems and solutions in the forum creates a record from which other members may benefit.

All copyrights and registered trademarks are property of their original owners. Any mention of trademarked or intellectual properties in this documents is purely for comparative purposes.

Parts Layout

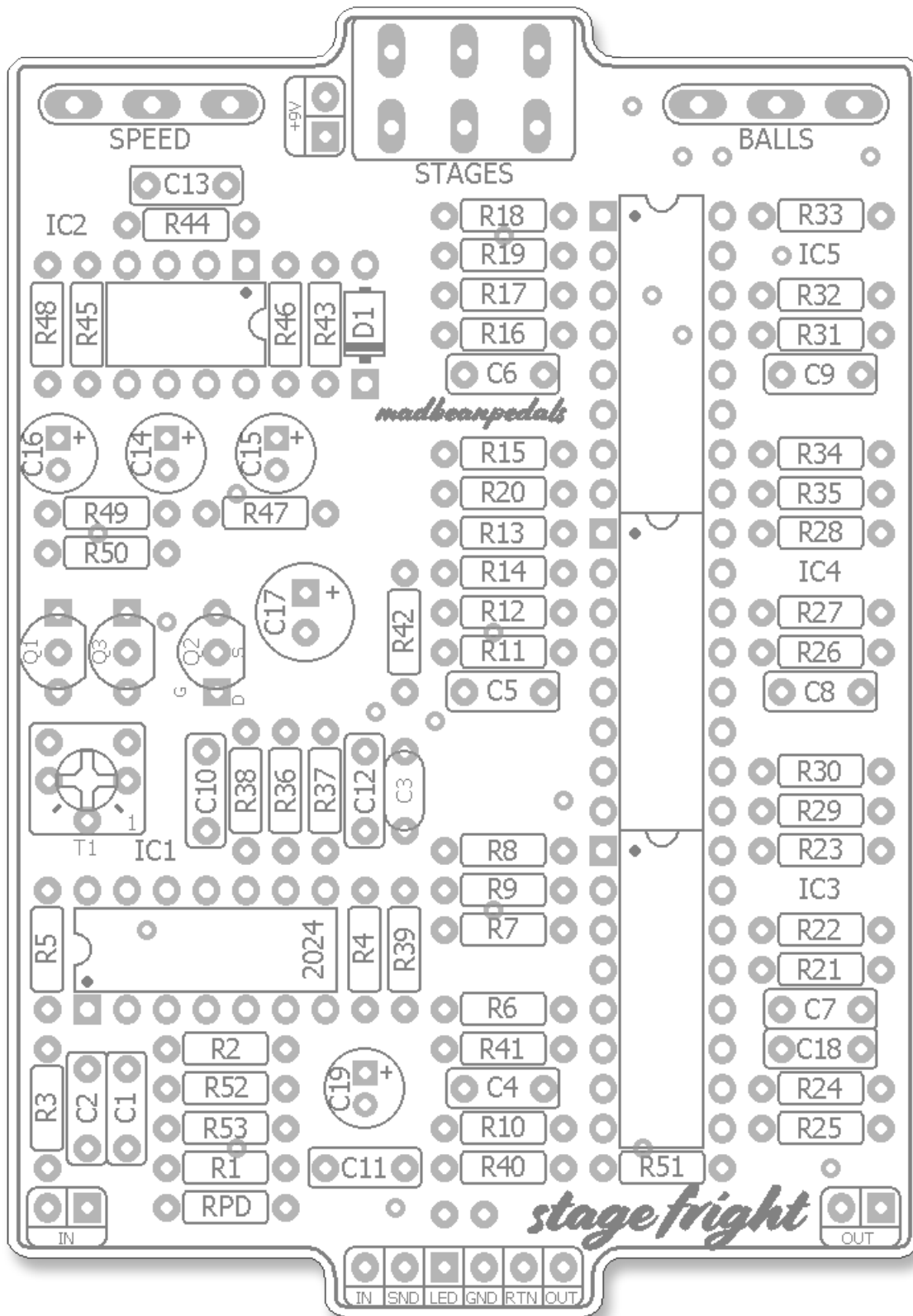

Trace Layout

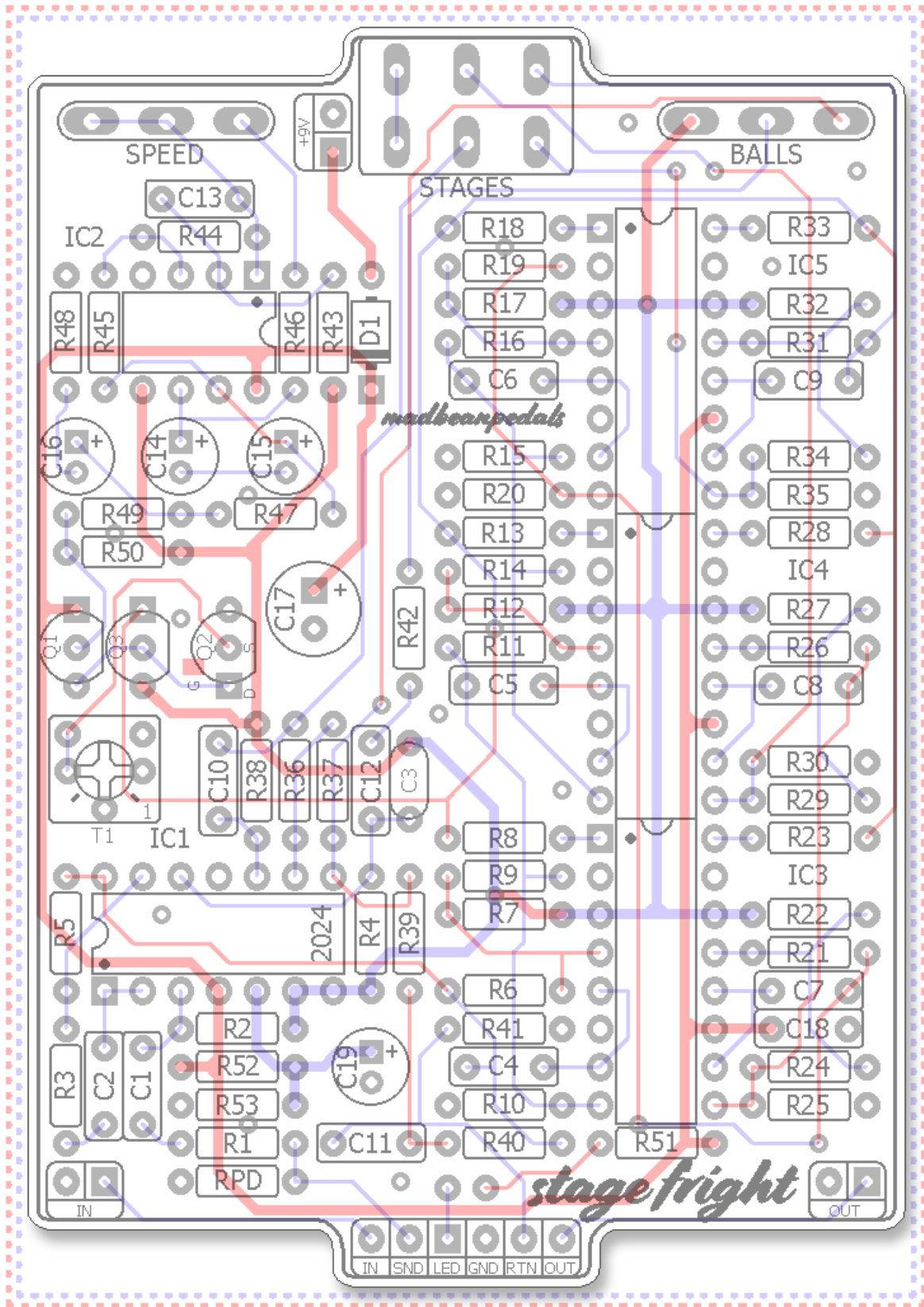

Wiring

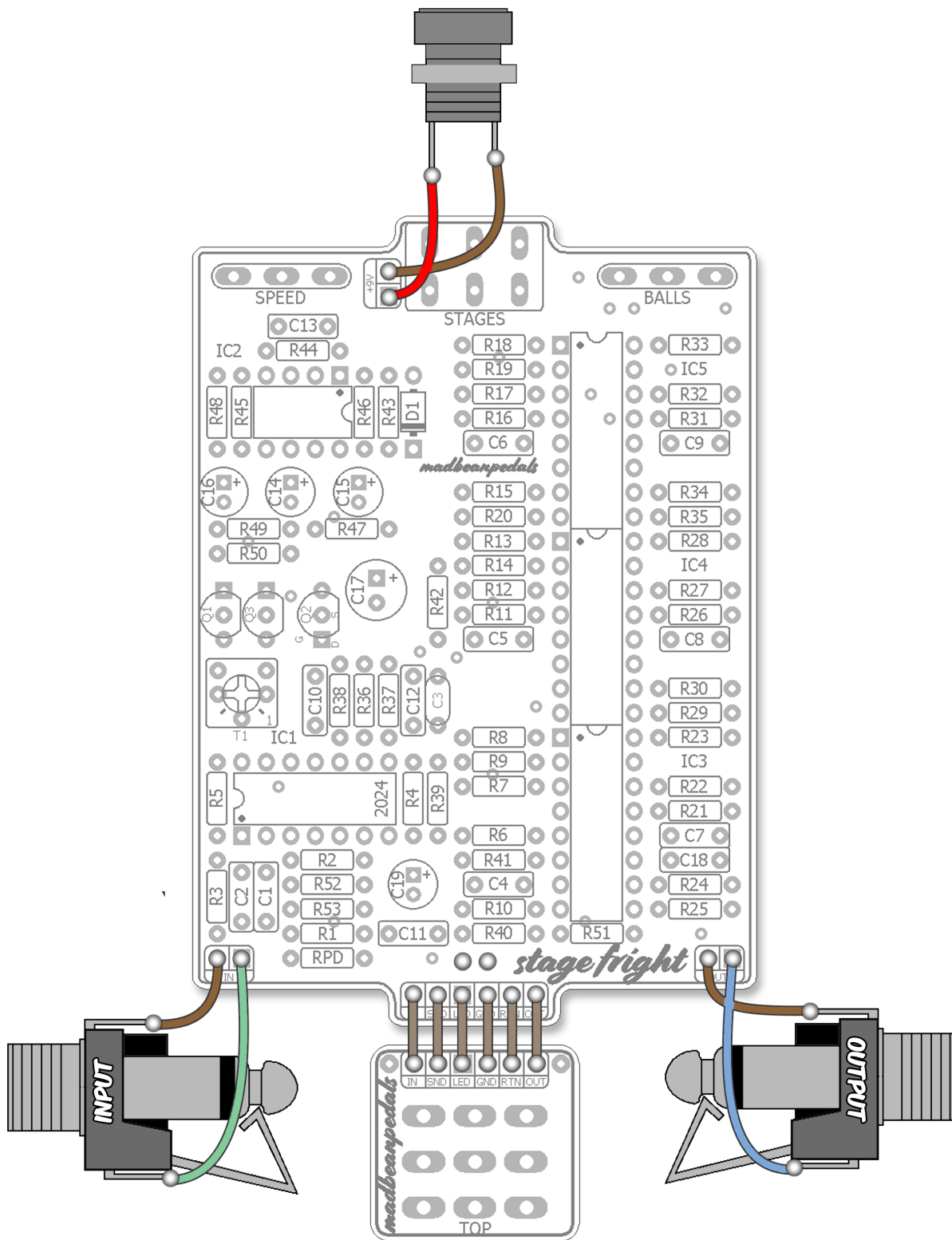

The 2024 version comes with its own bypass board and should be wired as shown above. The bypass LED is soldered directly to the bottom side of main board (directly above the I/O connections).

B.O.M.

Resistors		Resistors		Caps		Diodes	
R1	10k	R28	1k	C1	10n	D1	1n5817
R2	1M	R29	39k	C2	220n	ICs	
R3	33k	R30	20k	C3	220pF	IC1	TL074
R4	62k	R31	39k	C4	1n	IC2	TL062
R5	47k	R32	1k5	C5	1n	IC3	LM13700
R6	39k	R33	1k	C6	1n	IC4	LM13700
R7	1k5	R34	39k	C7	1n	IC5	LM13700
R8	1k	R35	20k	C8	1n	Transistors	
R9	39k	R36	390k	C9	1n	Q1	2n3904
R10	20k	R37	390k	C10	1n	Q2	2n5457
R11	39k	R38	200k	C11	220n	Q3	2N3906
R12	1k5	R39	10k	C12	220n	Switches	
R13	1k	R40	10k	C13	10n	STAGES	On/On
R14	39k	R41	1M	C14	10uF	Trimmers	
R15	20k	R42	120k	C15	10uF	T1	10k
R16	39k	R43	100k	C16	10uF	Pots	
R17	1k5	R44	300k	C17	220uF	BALLS	1MC
R18	1k	R45	100k	C18	100n	SPEED	1MC
R19	39k	R46	10k	C19	100uF		
R20	20k	R47	30k				
R21	39k	R48	3k				
R22	1k5	R49	30k				
R23	1k	R50	2k				
R24	39k	R52	100k				
R25	20k	R53	100k				
R26	39k	RPD	1M				
R27	1k5						

Shopping List

Value	QTY	Type	Rating
1k	6	Metal / Carbon Film	1/4W
1k5	6	Metal / Carbon Film	1/4W
2k	1	Metal / Carbon Film	1/4W
3k	1	Metal / Carbon Film	1/4W
10k	4	Metal / Carbon Film	1/4W
20k	6	Metal / Carbon Film	1/4W
30k	2	Metal / Carbon Film	1/4W
33k	1	Metal / Carbon Film	1/4W
39k	12	Metal / Carbon Film	1/4W
47k	1	Metal / Carbon Film	1/4W
62k	1	Metal / Carbon Film	1/4W
100k	4	Metal / Carbon Film	1/4W
120k	1	Metal / Carbon Film	1/4W
200k	1	Metal / Carbon Film	1/4W
300k	1	Metal / Carbon Film	1/4W
390k	2	Metal / Carbon Film	1/4W
1M	3	Metal / Carbon Film	1/4W
220pF	1	Ceramic / MLCC	16v min.
1n	7	Film	16v min.
10n	2	Film	16v min.
100n	1	Film	16v min.
220n	3	Film	16v min.
10uF	3	Electrolytic	16v min.
100uF	1	Electrolytic	16v min.
220uF	1	Electrolytic	16v min.
1n5817	1		
TL074	1		
TL062	1		
LM13700	3		
2n3904	1		
2n5457	1	or, J201 or MMBFJ201	
2N3906	1		
DPDT	1	On/On, Lug or Pin Mount	
10k	1	Bourns 3362p or 6mm	
1MC	2	PCB Right Angle	16mm

Additional Hardware

- (1) 125B enclosure
- (2) 1/4" mono jacks
- (1) Slim 2.1mm DC jack
- (1) Standard 3PDT footswitch
- (1) 5mm LED

Build Notes

The Stage Fright has two settings (via the Stages switch). In the left position, it is a stock MP-1. The stock setting is 5 swept stages plus 1 fixed stage (IC1_C) for a total of 6 (even). The right position adds one additional swept stage making the total 7 (odd). The two settings sound very different from each other. The left position has a very wide range of phase change and the right one is a more nasal/vocal sound.

You can use either a 2n5457 or J201 for Q2. There is also an option to use a surface mount device and it is soldered to the part as shown below.

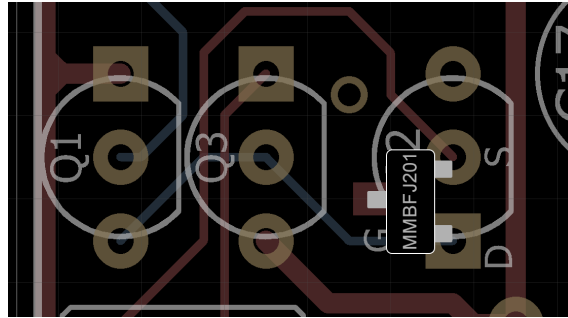

“RPD” is an input pulldown resistor not featured in the original design. There’s no reason not to use a pulldown (1M resistor) here so I recommend it.

Calibration

The only calibration required is adjusting the T1 trimmer. Looking at the schematic, it’s not immediately obvious what T1 does (at least it wasn’t to me in 2013 when I did the first version of the Stage Fright). Putting a scope on the LFO reveals all!

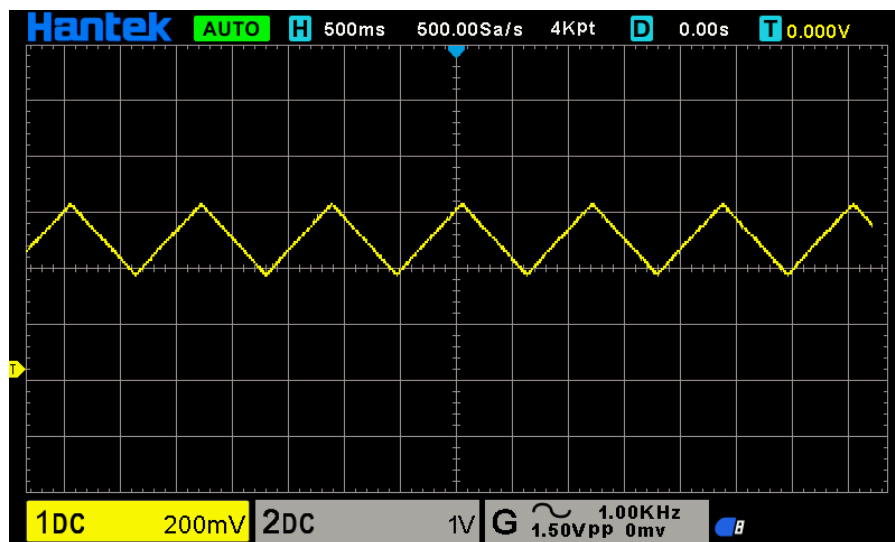

IC2, pin7 output. A simple triangle wave as one would expect.

Build Notes

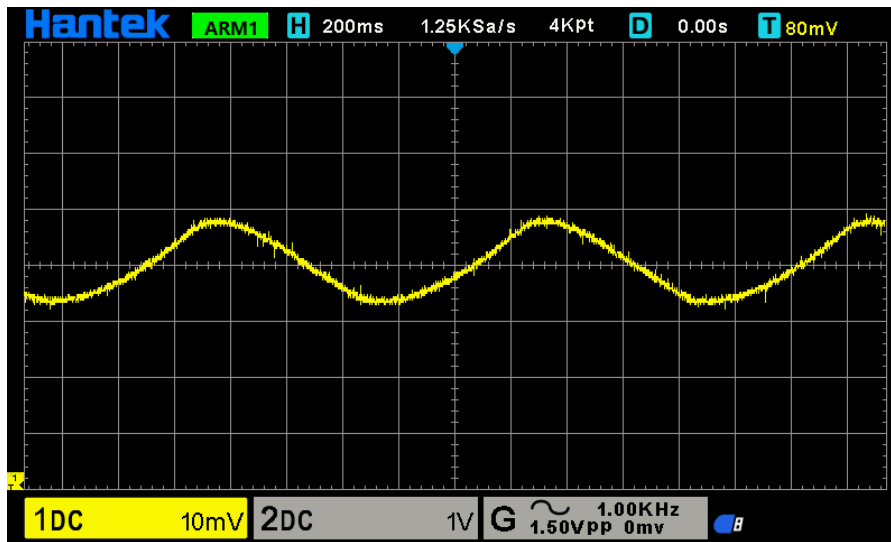

Q3 “VR” output after low pass filtering and T1 at the minimum setting. The triangle waveform has rounded off into an crude sine wave.

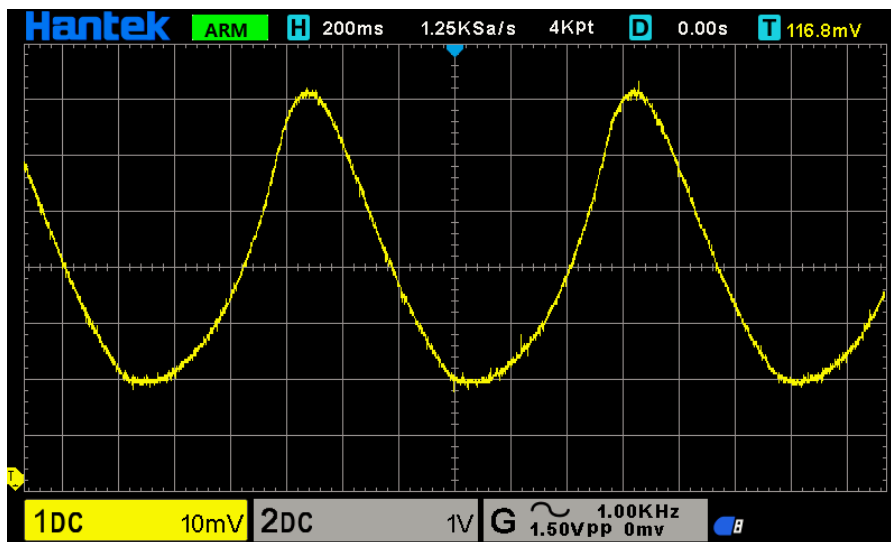

Same reading, with T1 at the max setting. Notice the increase in amplitude and a slight “retrianglization” (for lack of a better word) of the waveform.

So, T1 is a kind of depth control for the phaser. High settings produce greater depth but a narrowed peak on the waveform. Very low settings have a rounder waveform but less intensity. IOW, the best setting is somewhere between the two extremes. I suggest this approach: Set Speed, Balls and T1 fully CCW. Adjust T1 to get a fairly high depth without too narrow of a peak at the top and bottom of the phase sweep. Now increase the Balls setting and adjust T1 to taste. I found about 1/3rd up was the best setting. Above that, the low end starts to overwhelm the phase shifting esp. when Balls is set for high feedback.

Circuit Voltages

IC1	TL074	IC3	LM13700	IC4	LM13700	IC5	LM13700
1	4.61	1	~1.2	1	~1.2	1	~1.2
2	4.62	2	1.66	2	1.55	2	1.44
3	4.24	3	4.63	3	4.63	3	4.63
4	9.25	4	4.62	4	4.62	4	4.63
5	varies	5	~5.7	5	~5.7	5	~5.65
6	varies	6	0	6	0	6	0
7	varies	7	~5.7	7	~5.7	7	~5.65
8	~4.4	8	~4.59	8	~4.6	8	~4.6
9	~4.6	9	4.64	9	4.6	9	4.6
10	~4.5	10	~5.75	10	~5.7	10	~5.66
11	0	11	9.25	11	9.25	11	9.25
12	4.59	12	~5.75	12	~5.7	12	~5.66
13	4.62	13	4.63	13	4.63	13	4.63
14	4.63	14	4.63	14	4.63	14	4.63
IC2	TL062	15	1.33	15	1.38	15	1.42
1	varies	16	~1.2	16	~1.2	16	~1.2
2	~4.6	Q1	2n3904	Q2	2n5457	Q3	2n3906
3	varies	C	9.25	D	~4.02	C	~1.2
4	0	B	~4.63	S	392mV	B	~4.03
5	4.62	E	~4.02	G	0	E	4.63
6	4.62						
7	varies						
8	9.25						

- 9.42vDC One Spot
- Current Draw: 10mA (?!)
- Testing Conditions: Pots @ 12, switch left.
- Many voltages vary. I marked ones that were more or less concentrated around a specific value with a "~". Readings with a wide range were simply marked "varies".

Drill Template

Coordinates are denoted in (X,Y), drill size format starting from the center (0,0) location of the enclosure.

Tayda drill link: https://drill.taydakits.com/box-designs/new?public_key=ZmNIRmJTdHFuOVhLaVBQSVkwMkFmUT09Cg==

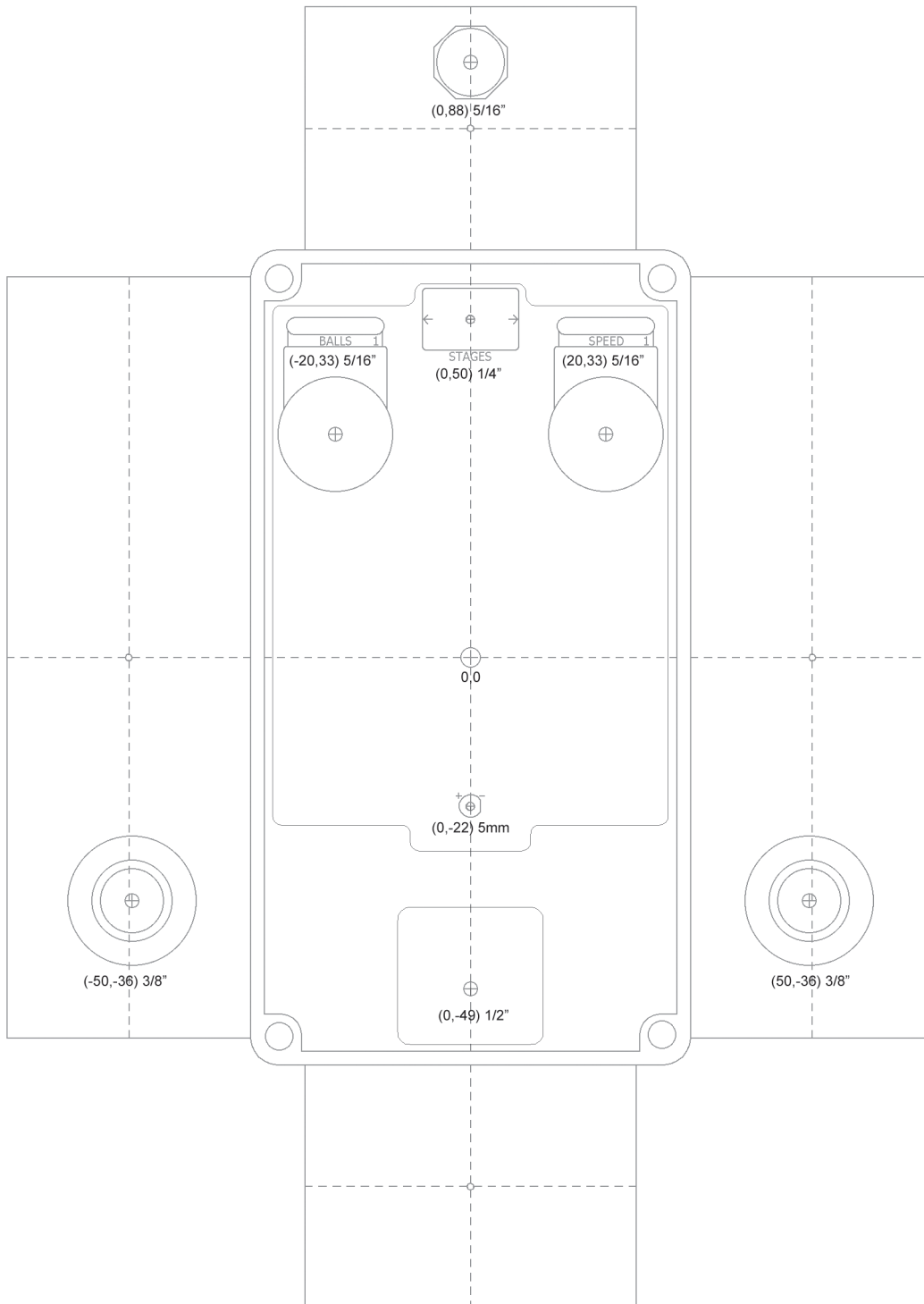

Hardware

125B enclosure

1/4" mono jacks

Slim 2.1mm DC jack

Standard 3PDT footswitch

5mm LED

NOTE: Different 1/4" and DC jack styles may require different sized drill holes.

Build Pic

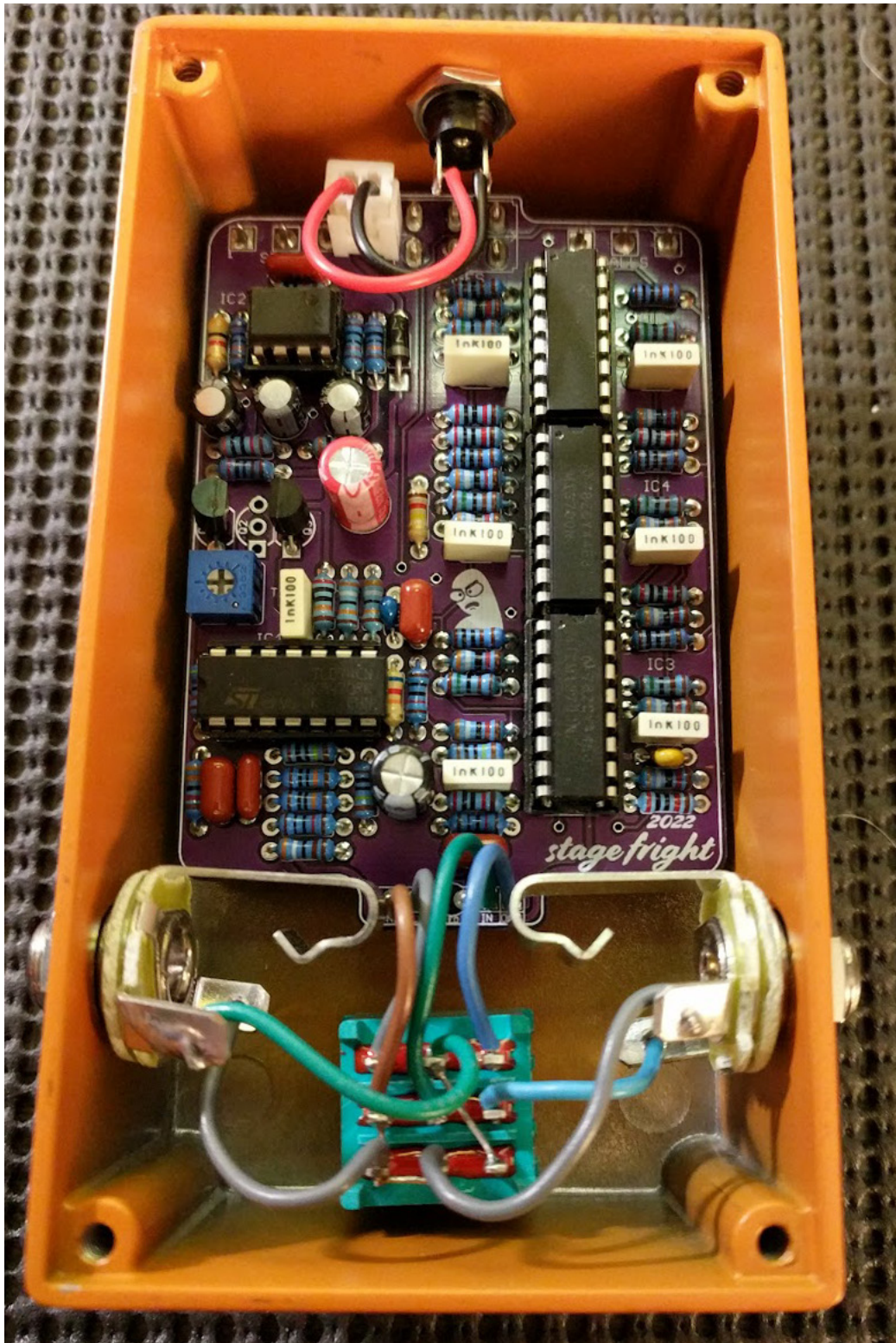

Previous version build.

Schematic

