

Polytrog24

FX Type: **MODULATION**

Build Level: Advanced

Based On: EHX® Polyphase™

Last Updated: August 17, 2024 5:57 PM

© 2024 [madbeanpedals](#)



The 2024 version of the **Polytrog** has no circuit changes and minor layout tweaks. A bypass board is now included with this version.

Overview

I don't think I can accurately describe just how much I grew to hate working on this project. Not that it is a bad effect (it's actually one of the best sounding optical phasers around). Rather, it turned into the longest development and most frustrating thing I've done for any pedal project, ever. I made numerous mis-steps and errors, put it aside for months at a time and built maybe seven prototypes to get it done. But, I never fully quit or gave up on it. Sometimes it does pay to stick with an idea even when you really want to give up!

The **Polytrog** is a clone of the vintage (big box) EHX Polyphase. At its core, the Polyphase is a six-stage optical phaser with a unique envelope control. This is the "quintessential" *lush* analog phaser, even though that term gets thrown around way too much. The combination of optical-based phasing with the high voltage operation puts the Polyphase in a unique category among many of its contemporaries and successors and a successful build on your part will no doubt find a good home on your pedalboard.

Controls

- **ENV/SWEEP:** The Polytrog has two modes: Envelope and Sweep. In sweep mode, the LFO is automatic and the phaser is controlled by the RATE and FDBK pots. In ENV mode, the Sweep LFO is disabled and a second, envelope driven LFO is enabled. Three controls (ENV SENSE, ENV MOD and MOD RATE) are available to change the dynamic response of the new LFO.
- **RATE:** The speed of the automatic LFO. This works only in the Sweep mode.
- **FDBK:** The amount of feedback sent from the output of the phase stages back to its input. IOW, a "swoosh" control. FDBK works regardless of what mode you are in.
- **ENV SENSE:** Controls the sensitivity of the envelope follower in ENV mode. This is keyed off playing dynamics. The higher the control, the more sensitive it is.
- **ENV RATE:** This sets the upper limit (speed) of the envelope controlled LFO in ENV mode.
- **ENV MOD:** The depth or intensity of the envelope controlled LFO in ENV mode.
- **T1:** This trimmer is used to set a fixed calibration point in the envelope circuit. See Notes.
- **T2:** This trimmer is to prevent runaway oscillation in the feedback path.

An older YouTube demo: <https://www.youtube.com/watch?v=f2wQstrdrfo>

Terms of Use: You are free to use purchased **Polytrog24** circuit boards for both DIY and small commercial operations. You may not offer **Polytrog24** PCBs for resale or as part of a "kit" in a commercial fashion. Peer to peer re-sale is fine, though.

Technical assistance for is available via the [madbeanpedals forum](#). Please go there rather than emailing me for personal assistance. This is because (1) I'm not always available to respond via email in a timely and continuous manner, and (2) posting technical problems and solutions in the forum creates a record from which other members may benefit.

All copyrights and registered trademarks are property of their original owners. Any mention of trademarked or intellectual properties in this documents is purely for comparative purposes.

Parts Layout

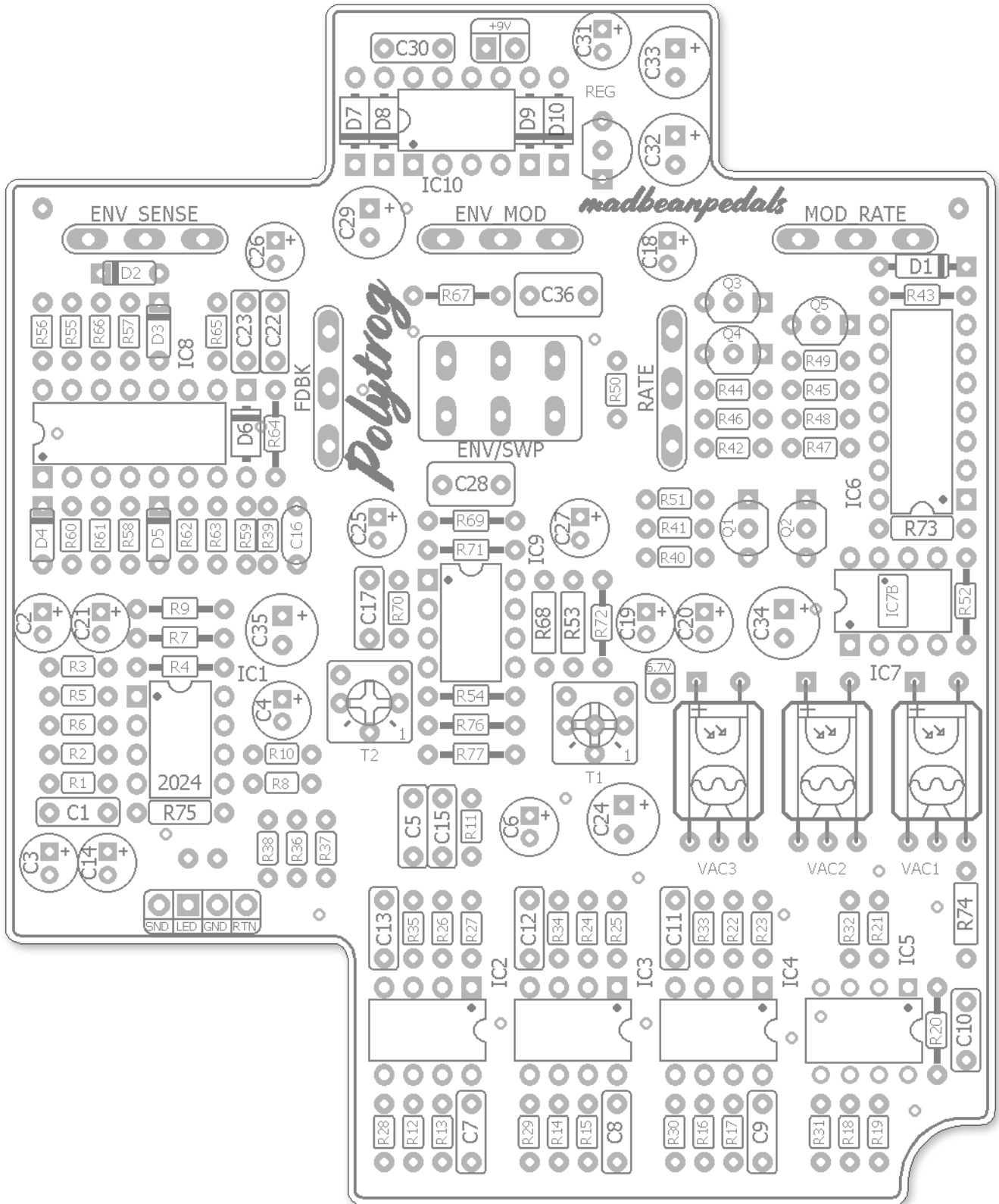

Trace Layout

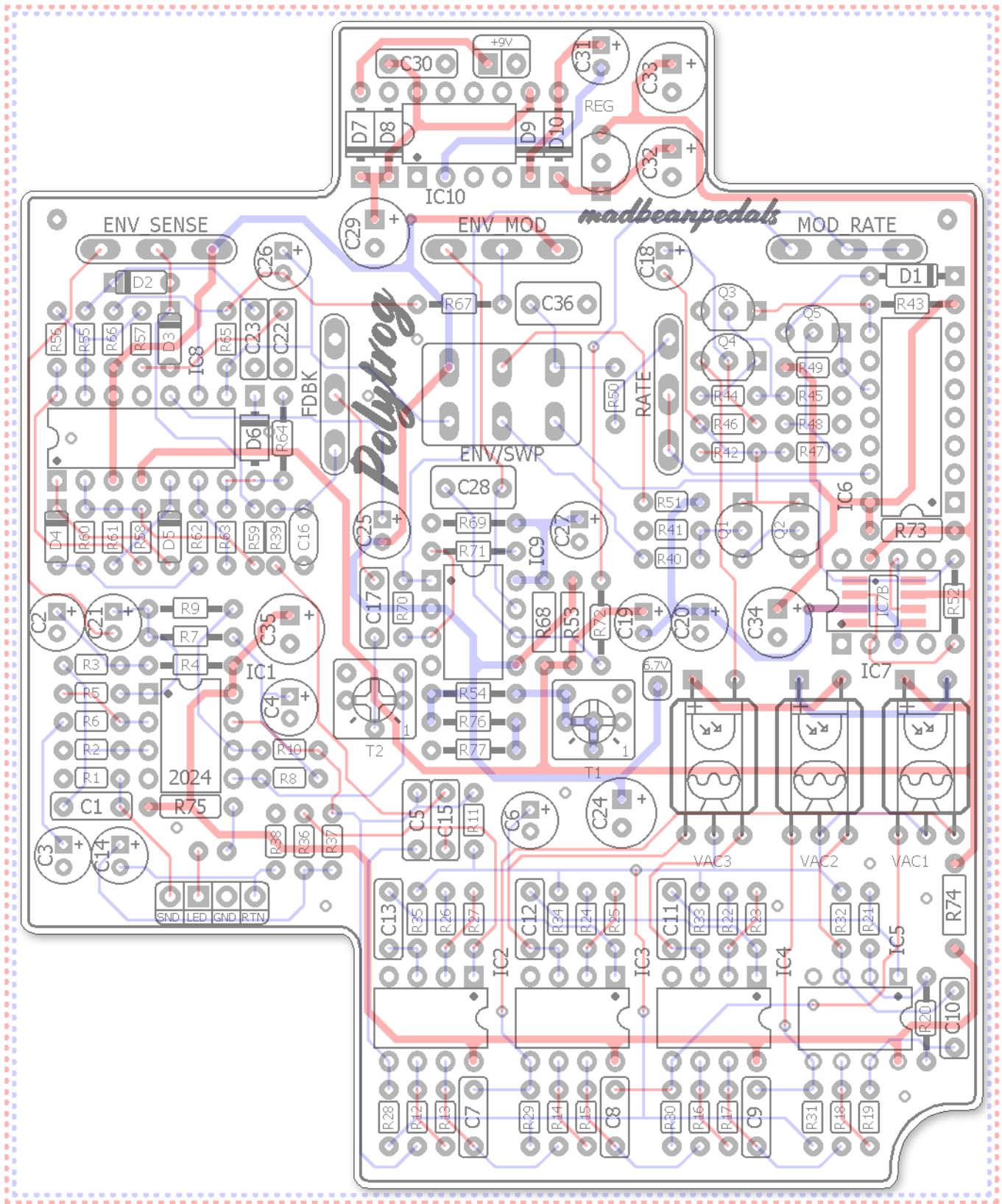

Wiring

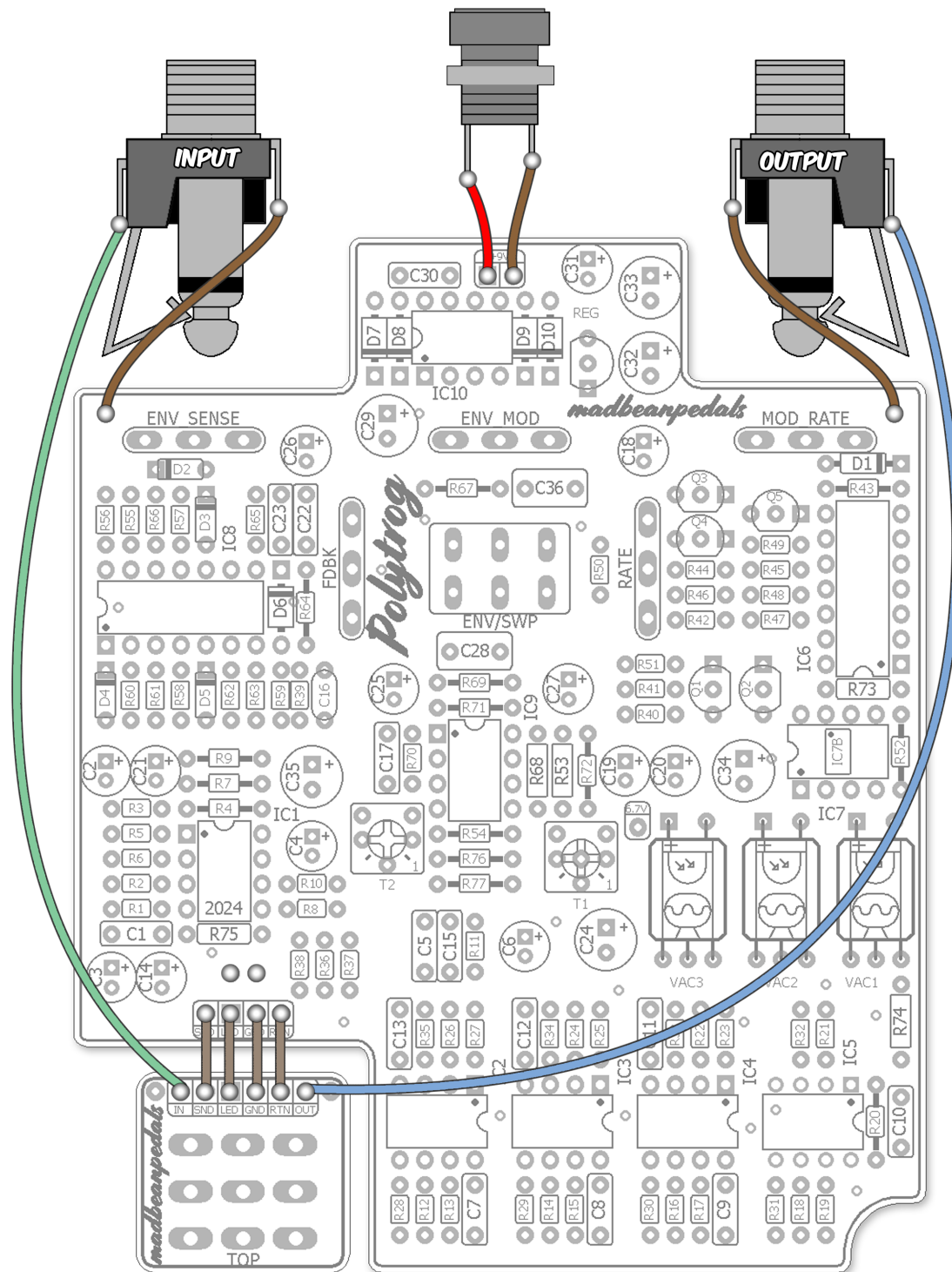

The Polytrog24 comes with its own bypass board and should be wired as shown above. The bypass LED is soldered directly to the bottom of the Polytrog PCB.

B.O.M.

Resistors		Resistors		Caps		Diodes		Trimmers	
R1	1M	R40	6k8	C1	47n	D1	1n914	T1	10K
R2	470k	R41	1k3	C2	1uF	D2	1n914	T2	250k
R3	390k	R42	390R	C3	1uF	D3	1n914	Pots	
R4	75k	R43	100k	C4	22uF	D4	1n914	ENV_MOD	100kB
R5	56k	R44	620k	C5	4n7	D5	1n914	ENV_SENSE	100kB
R6	56k	R45	56k	C6	22uF	D6	1n4001	FDBK	100kB
R7	100k	R46	51k	C7	10n	D7	1n5817	RATE	1MC
R8	220k	R47	100k	C8	10n	D8	15v Zener	MOD_RATE	1MC
R9	620k	R48	470k	C9	10n	D9	1n5817		
R10	620k	R49	100k	C10	10n	D10	1n5817		
R11	100k	R50	4k7	C11	10n	LED	any		
R12	36k	R51	18k	C12	10n	Transistors			
R13	18k	R52	4k7	C13	4n7	Q1	2N5088		
R14	15k	R53	15k	C14	1uF	Q2	2n3904		
R15	15k	R54	8k2	C15	5n6	Q3	2N5088		
R16	15k	R55	470k	C16	47pF	Q4	2N5087		
R17	15k	R56	240k	C17	8n2	Q5	2N5088		
R18	15k	R57	470k	C18	0.47uF	ICs			
R19	15k	R58	100k	C19	10uF	IC1	4558		
R20	15k	R59	100k	C20	10uF	IC2	4558		
R21	15k	R60	100k	C21	1uF	IC3	4558		
R22	15k	R61	100k	C22	22n	IC4	4558		
R23	15k	R62	100k	C23	22n	IC5	4558		
R24	15k	R63	100k	C24	220uF	IC6	CD4013		
R25	15k	R64	10k	C25	10uF	IC7	CA3140		
R26	18k	R65	39k	C26	1uF	IC8	LM324		
R27	36k	R66	4k7	C27	10uF	IC9	LM1458		
R28	22k	R67	820k	C28	330n	IC10	LT1054		
R29	100k	R68	330R	C29	220uF	Regulator			
R30	100k	R69	2k7	C30	100n	REG	78L15		
R31	100k	R70	15k	C31	47uF	Opto			
R32	100k	R71	12k	C32	100uF	VAC1 - 3	VTL5C3/2		
R33	100k	R72	75k	C33	100uF	Switch			
R34	100k	R73	100R	C34	100uF	ENV/SWP	On/On		
R35	43k	R74	100R	C35	100uF				
R36	3k6	R75	10k	C36	470n				
R37	3k6	R76	68k						
R38	15k	R77	Thermistor						
R39	82k								

Shopping List

Value	QTY	Type	Rating	Value	QTY	Type	Rating
100R	2	Metal / Carbon Film	1/4W	47pF	1	Ceramic / MLCC	25v min.
330R	1	Metal / Carbon Film	1/4W	4n7	2	Film	25v min.
390R	1	Metal / Carbon Film	1/4W	5n6	1	Film	25v min.
8k2	1	Metal / Carbon Film	1/4W	8n2	1	Film	25v min.
15k	1	Metal / Carbon Film	1/4W	10n	6	Film	25v min.
68k	1	Metal / Carbon Film	1/4W	22n	2	Film	25v min.
1k3	1	Metal / Carbon Film	1/8W	47n	1	Film	25v min.
2k7	1	Metal / Carbon Film	1/8W	100n	1	Film	25v min.
3k6	2	Metal / Carbon Film	1/8W	330n	1	Film	25v min.
4k7	3	Metal / Carbon Film	1/8W	470n	1	Film	25v min.
6k8	1	Metal / Carbon Film	1/8W	1uF	5	Film	25v min.
10k	2	Metal / Carbon Film	1/8W	0.47uF	1	Electrolytic	25v min.
12k	1	Metal / Carbon Film	1/8W	10uF	4	Electrolytic	25v min.
15k	14	Metal / Carbon Film	1/8W	22uF	2	Electrolytic	25v min.
18k	3	Metal / Carbon Film	1/8W	47uF	1	Electrolytic (low ESR)	25v min.
22k	1	Metal / Carbon Film	1/8W	100uF	4	Electrolytic	25v min.
36k	1	Metal / Carbon Film	1/8W	220uF	2	Electrolytic	16v min.
39k	1	Metal / Carbon Film	1/8W	1n914	5		
43k	1	Metal / Carbon Film	1/8W	1n4001	1		
51k	1	Metal / Carbon Film	1/8W	1n5817	3		
56k	3	Metal / Carbon Film	1/8W	LED	1	any	5mm
75k	2	Metal / Carbon Film	1/8W	15v	1	Zener, 1W	
82k	1	Metal / Carbon Film	1/8W	2n3904	1		
100k	17	Metal / Carbon Film	1/8W	2N5088	3		
220k	1	Metal / Carbon Film	1/8W	2N5087	1		
240k	1	Metal / Carbon Film	1/8W	4558	5		
390k	2	Metal / Carbon Film	1/8W	CD4013	1		
470k	4	Metal / Carbon Film	1/8W	CA3140	1	through-hole or smd	
620k	3	Metal / Carbon Film	1/8W	LM324	1		
820k	1	Metal / Carbon Film	1/8W	LM1458	1		
1M	1	Metal / Carbon Film	1/8W	LT1054	1		
Thermistor	1	*see notes		78L15	1	TO-92 style	
				VTL5C3/2	3	*see notes	
				DPDT	1	On/On, Solder Lug	
				10K	1	multi-turn trimmer	
				250k	1	Bourns 3362p or 6mm	
				100kB	3	PCB Right Angle	16mm
				1MC	1	PCB Right Angle	16mm

Additional Hardware

(1) 1590BB enclosure, (2) 1/4" mono jacks, (1) Slim 2.1mm DC jack, (1) Standard 3PDT footswitch

Shopping List

Multi-turn trimmer

<https://www.taydaelectronics.com/10k-ohm-trimmer-potentiometer-cermet-25-turns-3296w.html>

15v Zener:

<https://www.mouser.com/ProductDetail/512-1N4744A>

<https://www.taydaelectronics.com/1n4744a-1n4744-zener-diode-1w-13v.html>

LM78L15:

<https://www.mouser.com/ProductDetail/926-LM78L15ACZ-LFT4>

<https://smallbear-electronics.mybigcommerce.com/ic-78l15/>

<https://stompboxparts.com/semiconductors/lm78l15acz-voltage-regulator-15v/>

CD4013:

<https://www.mouser.com/ProductDetail/595-CD4013BE>

<https://smallbear-electronics.mybigcommerce.com/ic-cd4013/>

<https://stompboxparts.com/semiconductors/cd4013be-dual-flip-flop-ic/>

CA3140:

<https://www.mouser.com/ProductDetail/968-CA3140EZ>

<https://smallbear-electronics.mybigcommerce.com/ic-ca3140aez/>

LM1458:

<https://www.mouser.com/ProductDetail/595-MC1458P>

<https://stompboxparts.com/semiconductors/lm1458n-dual-op-amp-ic/>

LM324:

<https://www.mouser.com/ProductDetail/595-LM324N>

<https://smallbear-electronics.mybigcommerce.com/ic-lm324n/>

<https://stompboxparts.com/semiconductors/lm324n-quad-op-amp-ic/>

<https://www.taydaelectronics.com/lm324n-lm324-324-low-power-quad-op-amp-ic.html>

LT1054:

<https://stompboxparts.com/lt1054cp-charge-pump-ic/>

<https://www.taydaelectronics.com/lt1054-lt1054cp-charge-pump-switching-regulator-ic.html>

VTL5C3/2:

<https://cabintechglobal.com/vtl5c3-2>

<https://smallbear-electronics.mybigcommerce.com/photocoupler-dual-xvive-vtl5c3-2/>

<https://synhcube.com/cart/xvive-vactrol-vtl5c3-2-bag-of-2>

Build Notes

Power

Some of the oldest units used mains + transformer + regulator to operate the Polyphase at +15v. It would be better to require an 18v adapter for this project but since many people still consider that a “deal killer” I went with the conventional 9v power with charge pump as others have done. This circuit pushes the capabilities of the LT1054 slightly beyond its limit (which is 100mA current load). In Envelope mode it draws a modest 75mA. In Sweep mode current draw increases and appears to peak just north of 100mA. However, I’ve built the Polytrog several times over its production and feel confident the current draw does not hinder the performance or cause part failure. So, I stuck with the charge pump.

Optical

The Polyphase used 3 CLM8200/2 vactrol types for the optical phasing. These are hard to get (at least in the States) so I went with the modern Xvive reproductions of the VTL5C3/2 in the design. They work perfectly fine for the Polytrog. I was able to obtain three CLM from a fellow DIY’er after the design was completed and manufactured. I managed to fit them on my Polytrog board but it was nearly impossible. It simply wasn’t design for that footprint. So, I recommend stick with the VTL5C3/2. A/B’ing both versions gave very comparable results. Enough so that debate over any small difference between the two devices should be left to the purists.

Calibration

The envelope detector mode needs to be calibrated with the T1 10k multi-trimmer (included). The factory schem indicates this trimmer should be adjust to +6.7v. On the Polytrog PCB you will find a test point labeled “6.7v” that you can use for readings while adjusting the trimmer. I opted for the multi-turn trimmer because the calibration is very sensitive to small changes in voltage at the test point. When set to 6.7v, the MOD-RATE control produces very noticeable dynamic driven oscillation.

However, IF you set this voltage lower an interesting thing happens. The LFO becomes less sensitive and when you dial in high amounts of ENV_SENSE the response becomes a bit more like an auto-wah but with phaser. It sounds very cool and I liked it even more than the LFO. This happens around 6.3v-6.0v. Under 6v everything tends to wash out. So, I suggest playing with the calibration voltage a bit. In the end, I left mine at 6.3v because that gave a good balance between the LFO and quack.

Also note that the vintage Polyphase included a thermistor as part of the calibration circuit. This is a temperature sensitive resistor whose value changes according to the ambient temperature (the Polyphase one is spec’d 100k @ 25C). Having tested the Polytrog both with and without a thermistor it appears to not be needed, and many others have recommended the same in their clones. [This is a compatible thermistor](#) if you want to see for yourself. Just use a socket. The thermistor is labeled R77 on the Polytrog PCB.

TIP: When calibrating T1, keep all the knobs in the middle position and the in ENV mode (switch left).

The T2 trimmer is prevent oscillation in the feedback path. Set to ENV mode, Rate to about 1/3rd up. Now adjust the FDBK control all the way up, but slowly. If you start to get oscillation, turn T2 CW until it stops. Set T2 a the lowest clockwise turn that prevents oscillation at the highest FDBK setting.

Mods

C36 is indicated on the vintage circuit but it seems that this was marked DNP (do not populate) on the RI. My guess is that this cap was included to prevent any ticking from the main LFO circuit. Having tested the Polytrog, I could not detect any ticking even at max amp volume. You can use it if you like, or socket it and add it later if needed. I left an empty socket on my final build.

It’s possible the current draw in Sweep mode might be reduced by increasing the value of R73. Maybe 220R or 330R might help here. I did not test this, however, since my build was already boxed by the time I thought about it.

Circuit Voltages

IC1	4558	IC2	4558	IC3	4558	IC4	4558	IC5	4558	Q1	2n5088
1	6.44	1	6.4	1	6.29	1	6.41	1	6.31	C	varies
2	6.44	2	6.32	2	6.35	2	6.36	2	6.37	B	1.31
3	6.29	3	6.28	3	6.33	3	6.34	3	6.34	E	0.75
4	0	4	0	4	0	4	0	4	0	Q2	2n3904
5	6.28	5	6.3	5	6.32	5	6.33	5	6.33	C	varies
6	6.47	6	6.33	6	6.33	6	6.34	6	6.35	B	1.31
7	6.46	7	6.27	7	6.41	7	6.3	7	6.41	E	0.76
8	13.25	8	13.25	8	13.25	8	13.25	8	13.25	Q3	2n5088
IC6	CD4013	IC7	CA3140	IC8	LM324	IC9	LM1458	IC10	LT1054	C	varies
1	14.98	1	ignore	1	5.79	1	varies	1	1.98	B	0.56
2	0	2	8.17	2	6.98	2	6.13	2	4.89	E	0
3	0	3	varies	3	6.18	3	varies	3	0	Q4	2n5087
4	0	4	0	4	15.01	4	0	4	0	C	~10v
5	0	5	ignore	5	7.2	5	6.13	5	0	B	9.8
6	0	6	varies	6	7.01	6	6.14	6	2.57	E	~10v
7	0	7	15.01	7	6.2	7	varies	7	1.34	Q5	2n5088
8	varies	8	ignore	8	6.8	8	12.25	8	9.18	C	varies
9	0			9	6.2					B	~1.1
10	varies			10	6.2					E	varies
11	0			11	0					REG	78L15
12	0			12	6.14					I	17.11
13	0			13	7.01					G	0
14	14.98			14	6.2					O	15.01

- 9.42vDC Power Supply
- Current Draw: ~75 - 105mA
- Testing Conditions: All knobs CCW, switch in the right position.

Drill Template

Coordinates are denoted in **(X,Y)**, **drill size** format starting from the center (0,0) location of the enclosure.

Tayda drill template: https://drill.taydakits.com/box-designs/new?public_key=TWF2ZjVjeVF5YINvc1RHWjl5NE5uZz09Cg==

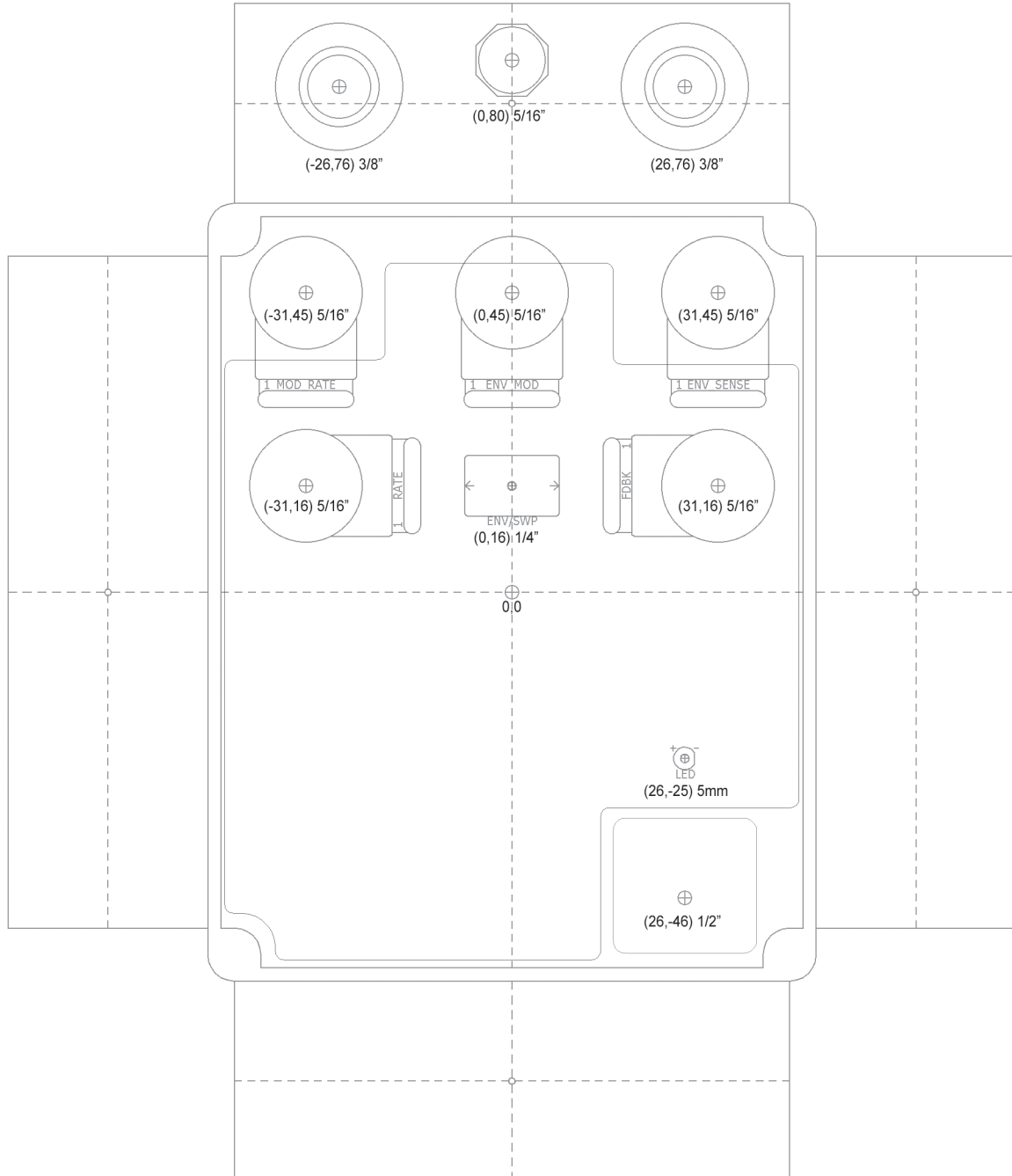

Hardware

1590BB enclosure
Mono jacks
Slim 2.1mm DC jack
Standard 3PDT footswitch

NOTE: Different 1/4" and DC jack styles may require different sized drill holes.

Build Pic

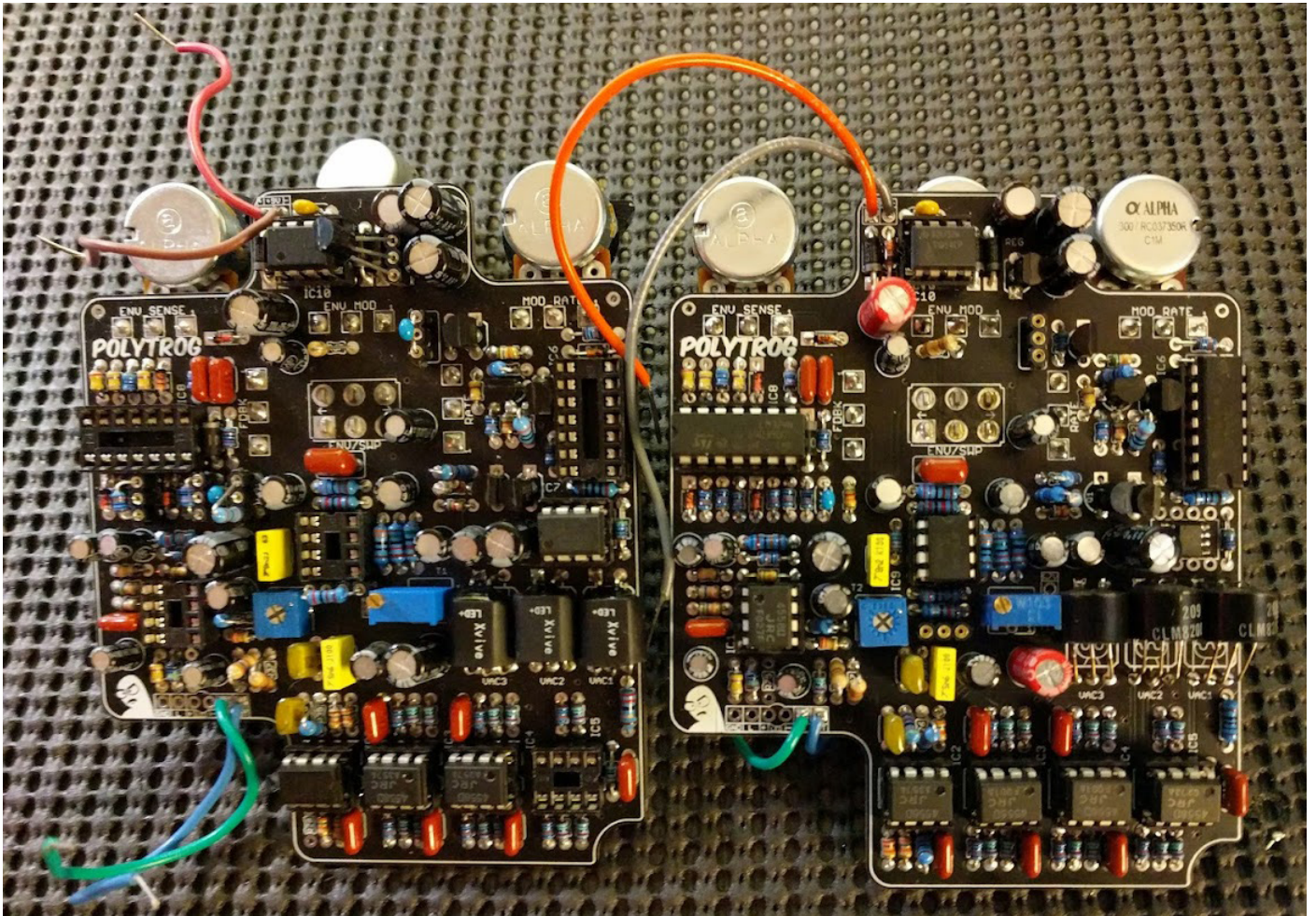

Previous version builds

Schematic

