

Kezuroukai24

FX Type: **MODULATION**

Build Level: Intermediate

Based On: Blackstone Effectors® Whetstone™

Last Updated: August 18, 2024 10:39 AM

© 2024 [madbeanpedals](#)



The 2024 version of the **Kezuroukai** has no circuit changes and brand a new layout. The design has been converted from 2-layer to 4-layer and the control layout has been changed to resemble the commercial version.

Overview

Kezurou-kai is a term that has become synonymous with the practice (and competition) of Japanese wood planing. It involves using fine hand planes to shave off ever thinner wood spirals. The thickness of the planed wood fibers is a testament to the artistry of the woodworker and his or her tool. Some competitors are able to achieve results comparable to the width of a single human hair. It reveals the devotion it takes to elevate the practice of a skill to perfection. What does this have to do with Phasers? Why, nothing at all! But, if you've been doing DIY for a long while you might have an understanding (or at least an appreciation) for the time and devotion it takes to master a skill and evolve into a true craftsman.

The Kezuroukai project is based on the Blackstone Effectors Whetstone™ phaser. This is a highly tweakable phase effect that has roots in the OTA Ross and Small Stone. If you love phaser (and I know someone who does) you will love the Kezuroukai. It's got something for all phlovers, one might say.

Controls

- **RATE (pot):** Sets the LFO rate from slow to fast.
- **DEPTH (pot):** The overall depth or intensity of the phaser or vibrato.
- **FEEDBACK (pot):** The resonance of the phase stages. At the highest settings you may hear the overall output volume dip. This is normal. At that point the feedback is actually loading down the input signal. Around 2/3rds up seems to be where the thickest "whoosh" resides.
- **VOL (pot):** Output level.
- **SWEEP (switch):** Sets the overall range from center of the LFO sweep. The two settings are Shallow and Wide. This switch has some interaction with the Rate and Range controls.
- **STAGES (switch):** Toggles between 2 and 4 phase stages.
- **SYM (switch):** This switches the two middle all-pass stages to asymmetrical. What this means is rather than having 4 stages of identical all-pass stages, two of them will have slightly different filtering creating an asymmetry in the total phase sweep. This switch setting can also alter the behavior of the Filter switch. This switch may pop a bit when you first engage it.
- **FILTER (switch):** This switch converts the third and fourth all-pass phase stages to low-pass by sending the filter caps to virtual ground. It interacts with the Stages switch, as well. In 4-stage mode you will have two all-pass stages followed by two low-pass stages. In 2-stage mode you will have just the two low pass stages.
- **VIB (switch):** Removes the input signal from the phaser to produce a vibrato effect.
- **RANGE (rotary):** This rotary sets the total range of the LFO. It has four settings: Normal (a general phaser LFO range), Pads (an extremely slow LFO sweep), Ring (a super fast LFO sweep that can create ring mod type effects) and Fixed. The Fixed setting disengages the LFO sweep. Here you can use the Rate as a manual control to create different filter effects.
- **T1 (trimmer):** This trimpot sets the gain of the output stage before the volume control. It is completely user-preference. You can set it for clean output or slight break-up by turning the trimmer CW.

Terms of Use: You are free to use purchased **Kezuroukai24** circuit boards for both DIY and small commercial operations. You may not offer **Kezuroukai24** PCBs for resale or as part of a "kit" in a commercial fashion. Peer to peer re-sale is fine, though.

Technical assistance for is available via the [madbeanpedals forum](#). Please go there rather than emailing me for personal assistance. This is because (1) I'm not always available to respond via email in a timely and continuous manner, and (2) posting technical problems and solutions in the forum creates a record from which other members may benefit.

All copyrights and registered trademarks are property of their original owners. Any mention of trademarked or intellectual properties in this documents is purely for comparative purposes.

Parts Layout

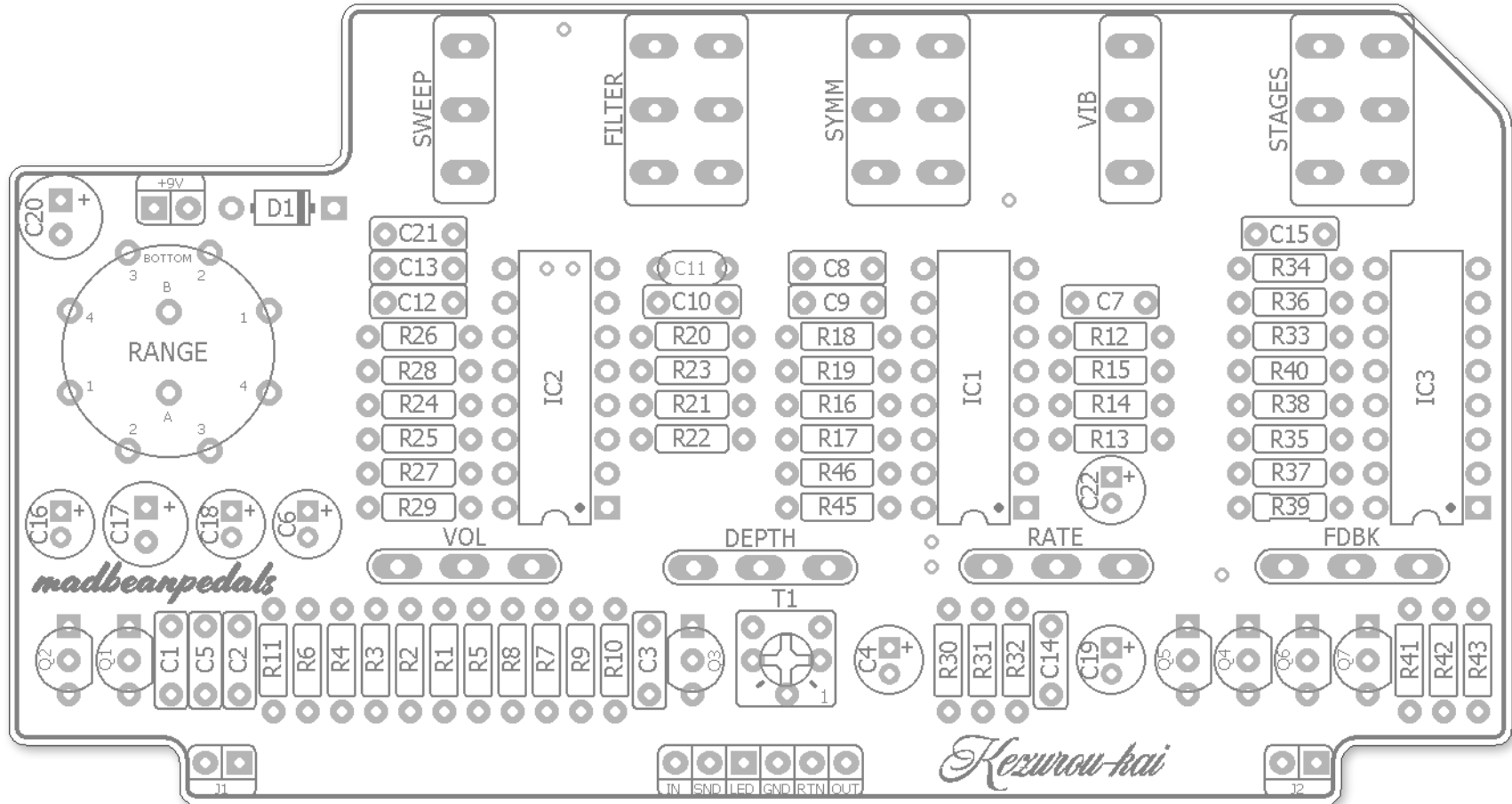

Traces - Outer

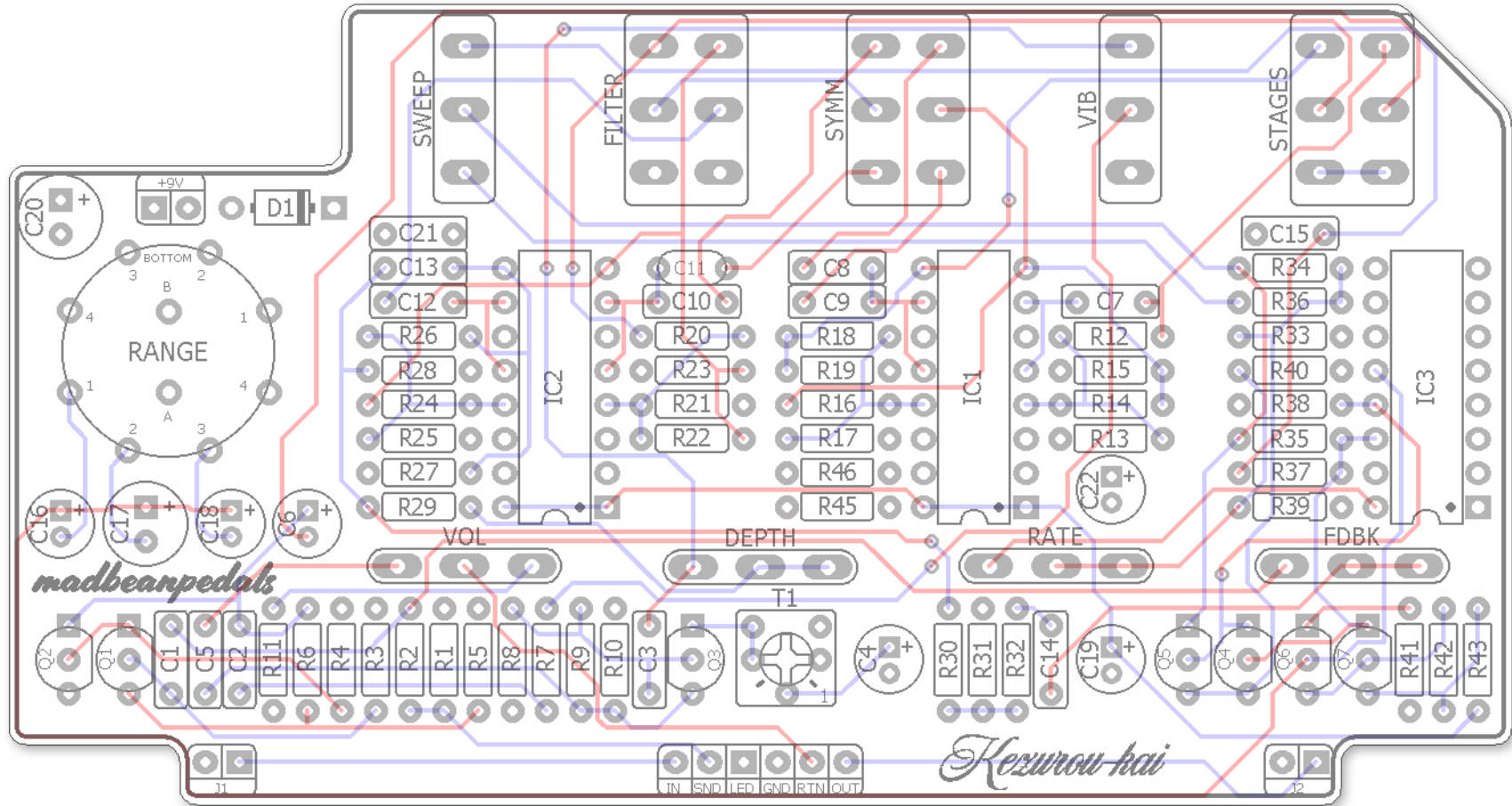

Traces - Inner

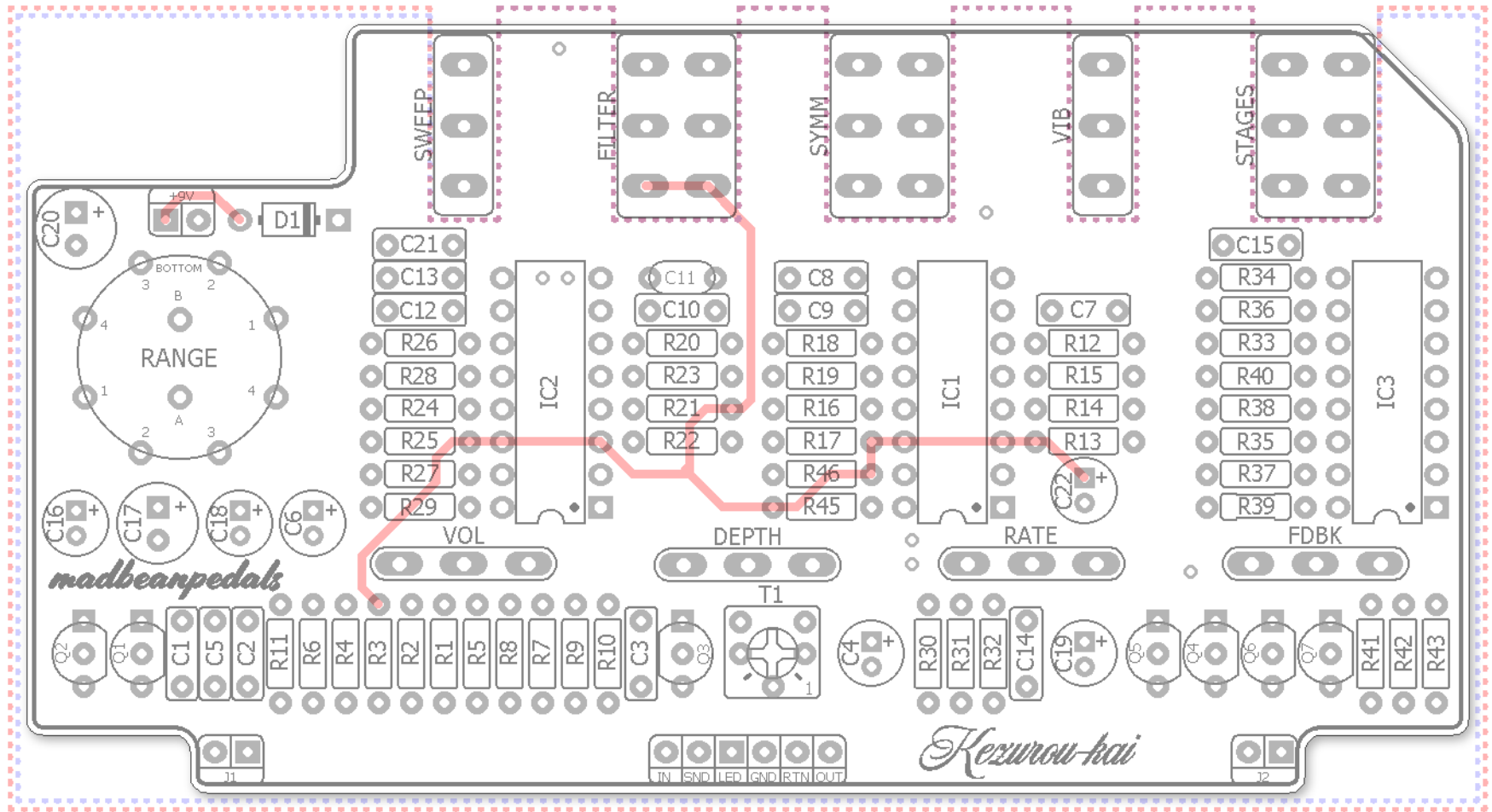

Wiring

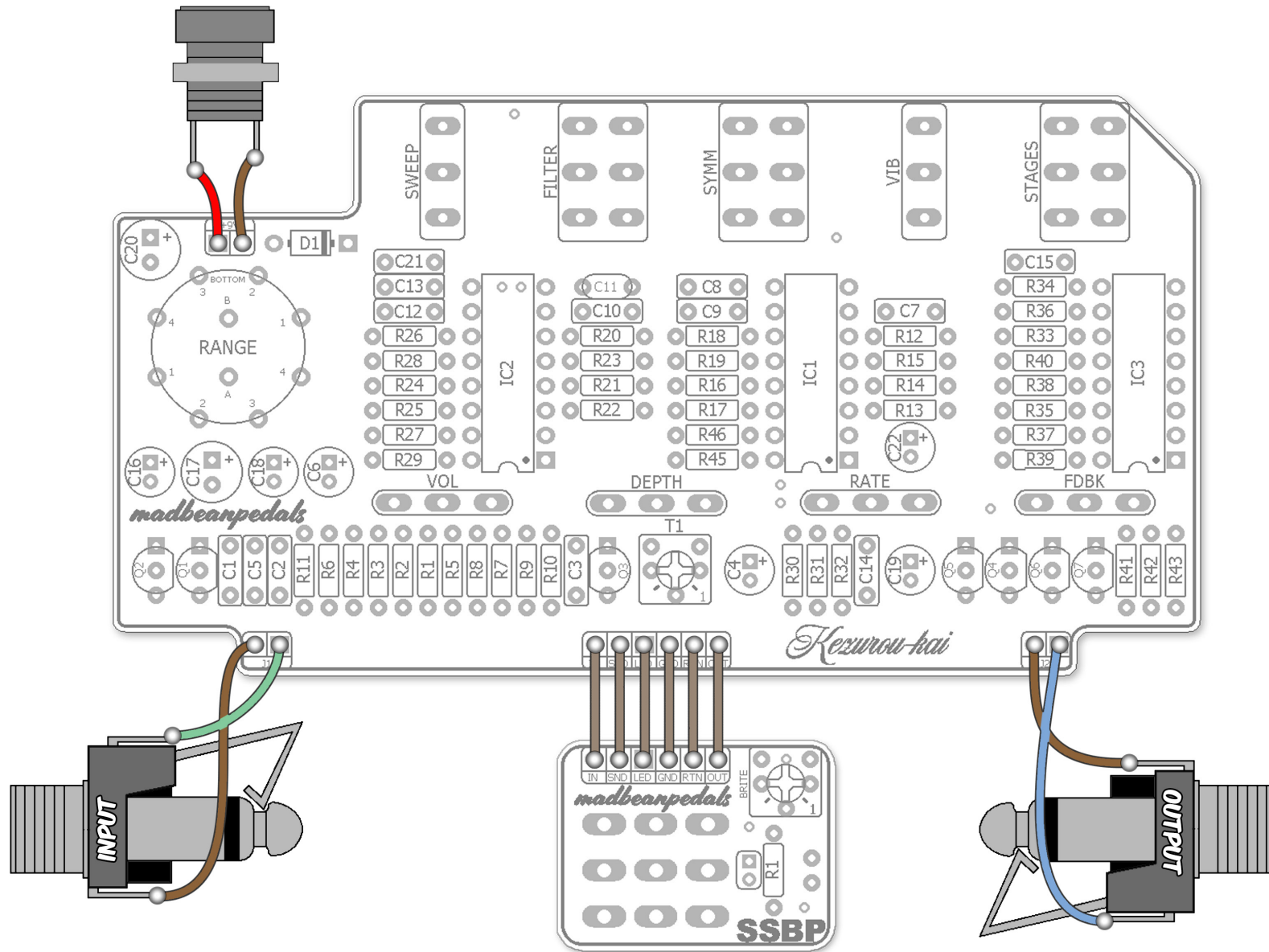

The Kezuroukai is compatible with the **SSBP** bypass board available at madbearpedals.

B.O.M.

Resistors		Resistors		Caps		Diodes	
R1	2M2	R23	10k	C1	6n8	D1	1N5817
R2	100k	R24	27k	C2	100n	Transistors	
R3	470k	R25	1k	C3	100n	Q1	2N5088
R4	10k	R26	27k	C4	22uF	Q2	2N5087
R5	4k7	R27	10k	C5	100n	Q3	2N7000
R6	4k7	R28	27k	C6	10uF	Q4, Q5	2N5087
R7	27k	R29	22k	C7	6n8	Q6, Q7	2N5088
R8	2M2	R30	3k3	C8	6n8	ICs	
R9	2M2	R31	4k7	C9	220n	IC1 - IC3	LM13700
R10	10k	R32	27k	C10	6n8	Switches	
R11	10k	R33	4k7	C11	680pF	FILTER	ON/ON
R12	27k	R34	15k	C12	6n8	STAGES	ON/ON
R13	1k	R35	1k	C13	47n	SWEEP	ON/ON
R14	27k	R36	22k	C14	47n	SYMM	ON/ON
R15	10k	R37	1k8	C15	100n	VIB	ON/ON
R16	27k	R38	27k	C16	22uF	Rotary	
R17	1k	R39	27k	C17	100uF	RANGE	2P4T
R18	27k	R40	15k	C18	1uF	Trimmer	
R19	10k	R41	1k8	C19	22uF	T1	10k
R20	27k	R42	47k	C20	100uF	Pots	
R21	1k	R43	100R	C21	100n	VOL	100kA
R22	27k	R44	4k7	C22	10uF	DEPTH	250kB
		R45	27k			FDBK	250kB
		R46	27k			RATE	1MC

2P4T Rotary Switch:

<https://stomiboxparts.com/switches/2p4t-mini-rotary-switch/>

Shopping List

Value	Qty	Type	Rating
100R	1	Metal / Carbon Film	1/8W
1k	5	Metal / Carbon Film	1/8W
1k8	2	Metal / Carbon Film	1/8W
3k3	1	Metal / Carbon Film	1/8W
4k7	5	Metal / Carbon Film	1/8W
10k	7	Metal / Carbon Film	1/8W
15k	2	Metal / Carbon Film	1/8W
22k	2	Metal / Carbon Film	1/8W
27k	15	Metal / Carbon Film	1/8W
47k	1	Metal / Carbon Film	1/8W
100k	1	Metal / Carbon Film	1/8W
470k	1	Metal / Carbon Film	1/8W
2M2	3	Metal / Carbon Film	1/8W
680pF	1	Ceramic / MLCC	
6n8	5	Film	
47n	2	Film	
100n	5	Film	
220n	1	Film	
1uF	1	Electrolytic	
10uF	2	Electrolytic	
22uF	3	Electrolytic	
100uF	2	Electrolytic	
1N5817	1		
2N5088	3		
2N5087	3		
2N7000	1		
LM13700	3		
SPDT	2	On/On, Solder Lug	
DPDT	3	On/On, Solder Lug	
2P4T	1	Rotary	
10k	1	Bourns 3362p or 6mm	
100kA	1	PCB Right Angle	16mm
250kB	2	PCB Right Angle	16mm
1MC	1	PCB Right Angle	16mm

Additional Hardware

- (1) 1590BB enclosure
- (2) 1/4" mono jacks
- (1) Slim 2.1mm DC jack
- (1) Standard 3PDT footswitch
- (1) 5mm LED

Build Notes

This is one of those projects where the fundamental circuit is not very complicated, but the build itself is made complicated by the vast array of controls available. My build advice is after you have all the basic components in, then solder the 16mm pots, then the toggle switches (leave the rotary for last) The key to soldering so many switches is to use some Blue Tac to fix a switch in place, solder in one lug, check the positioning, then solder the remainder of the lugs. If your switch gets slightly askew, you can always remelt that first solder while repositioning the switch then finish the rest of the lugs. If you pre-drill an enclosure for this project then you can assemble and solder the hardware in place to ensure everything is lined up properly.

Spend some time getting to know the many different settings. There are some surprising effects available beyond just phasing. One note: the FIXED setting can be noisy. But, if you dial it in just right there are some ring-mod like tones to be found.

Circuit Voltages

IC1	LM13700	IC2	LM13700	IC3	LM13700	Q1	2N5088	Q5	2N5087
1	~1.2	1	~1.2	1	-	C	8.55	C	~6.5
2	-	2	-	2	-	B	4.26	B	6.5
3	4.54	3	4.54	3	-	E	3.95	E	6.8
4	4.54	4	4.54	4	-	Q2	2N5087	Q6	2N5088
5	5.65	5	5.65	5	-	C	7.58	C	9.16
6	0	6	0	6	0	B	8.55	B	varies
7	5.65	7	5.65	7	-	E	9.17	E	1.79
8	4.53	8	4.53	8	-	Q3	2N7000	Q7	2N5088
9	4.53	9	4.53	9	-	D	7.43	C	varies
10	5.66	10	5.66	10	-	G	3.49	B	1.79
11	9.18	11	9.18	11	9.18	S	1.69	E	~1.2
12	5.67	12	5.67	12	~2.3	Q4	2N5087		
13	4.54	13	4.54	13	~6.5	C	6.5		
14	4.63	14	4.63	14	~6.5	B	varies		
15	-	15	-	15	~2.6	E	6.8		
16	~1.2	16	~1.2	16	~1.2				

- 9.42vDC One Spot
- Current Draw ~ 7mA
- Voltages for unconnected pins in circuit have been ignored.
- Some readings will vary around the LFO and may change with different switch or pot settings.

Drill Template

Coordinates are denoted in (X,Y), drill size format starting from the center (0,0) location of the enclosure.

Tayda drill link: https://drill.taydakits.com/box-designs/new?public_key=ZEc1bXlhUm9qVDBhNXM0OE1WM2I3UT09Cg==

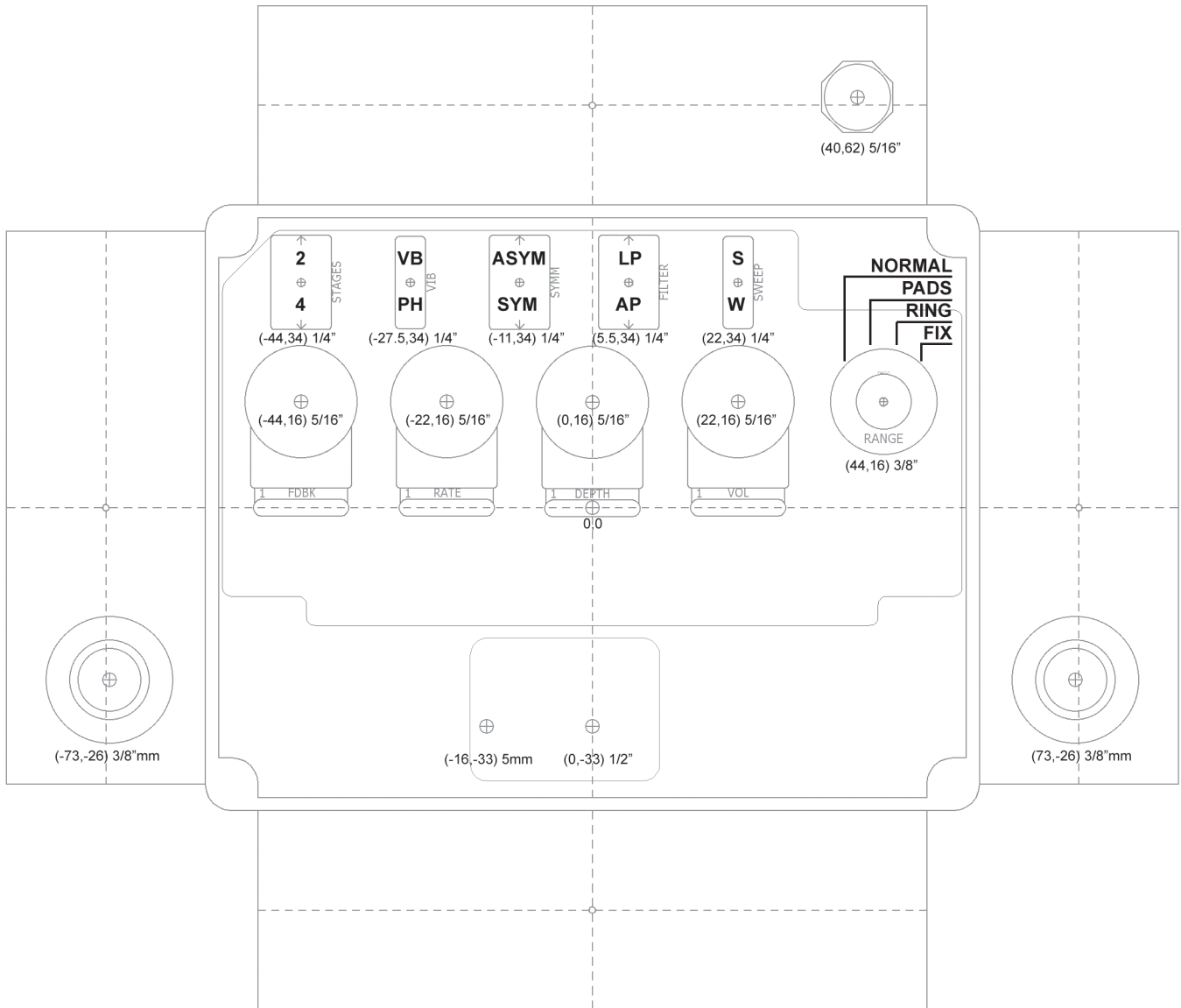

Hardware

1590BB enclosure
1/4" mono jacks
Slim 2.1mm DC jack
Standard 3PDT footswitch
5mm LED

NOTE: Different 1/4" and DC jack styles may require different sized drill holes.

Build Pic

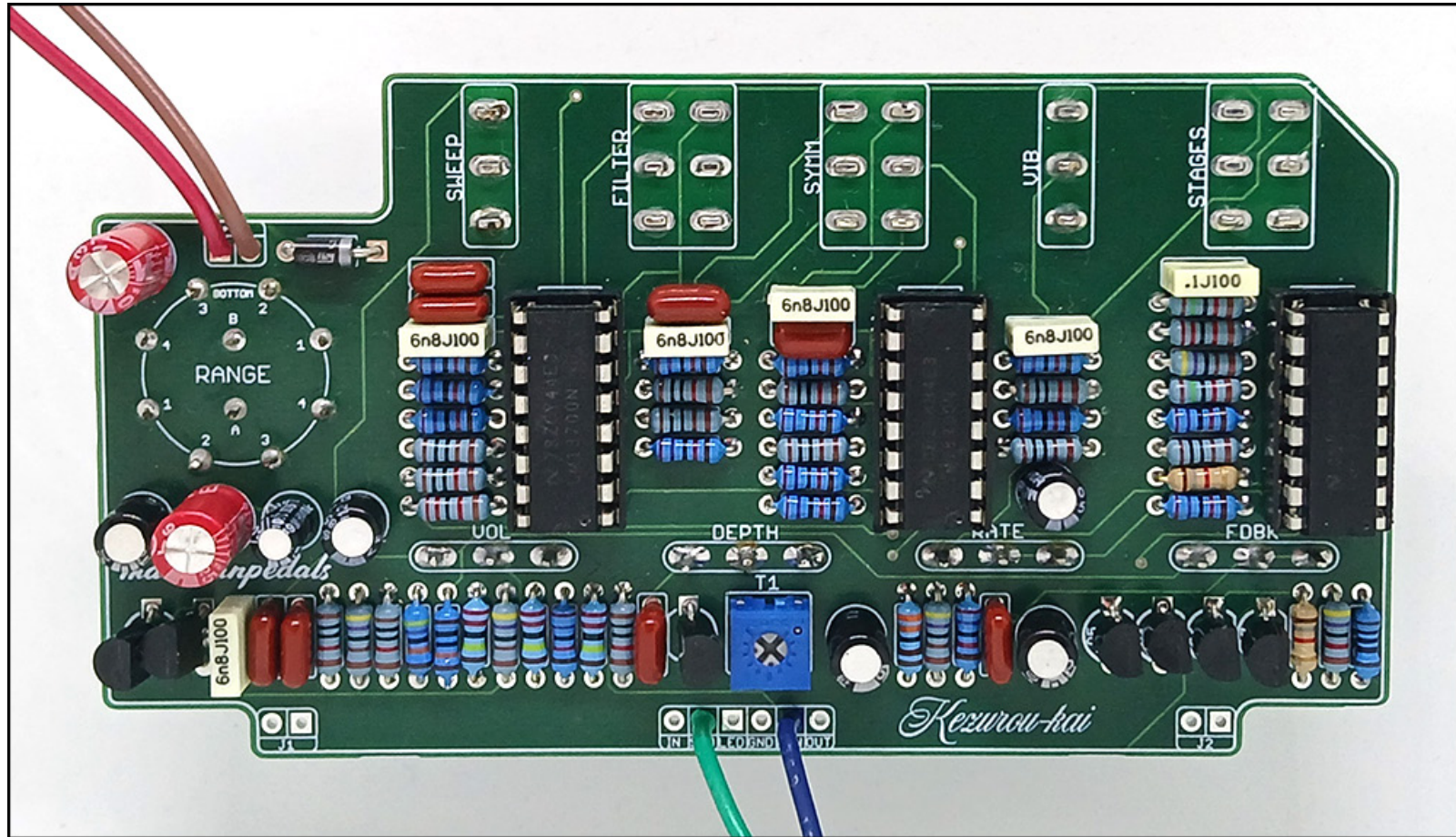

Schematic

