

Florist24

FX Type: **MODULATION**

Build Level: Intermediate

Based On: Little Angel Chorus

Last Updated: August 17, 2024 11:19 AM

© 2024 [madbeanpedals](#)



The 2024 version of the Florist has no circuit changes and minor layout tweaks.

Overview

The Florist is a PT-2399 based chorus capable of a wide range of chorus, vibrato and lots of modulated weirdness beyond that. It's based around the Little Angel chorus which has been a DIY staple for many years. My goal was to expand the design with additional features to make it a "multi-trick" pony.

The added features include width and feedback controls, a different audio-through section and running the PT2399 at a slightly higher voltage. These additions make for a well-rounded effect but without the complexity or expense of utilizing a BBD/Clock to create the chorus effect.

Much credit goes to Rick Holt for the original Little Angel design!

Controls

- **SPD:** Chorus/Vibrato rate from slow to fast.
- **DEPTH:** Chorus/Vibrato depth from min to max.
- **WIDTH:** Displaces the LFO waveform by making the peaks and valleys uneven (similar to altering the duty cycle). It also creates a bit of "throb" at the highest setting.
- **BLOOM:** Acts as feedback for the delayed output signal. It can create some pseudo-flange sounds in conjunction with the WIDTH and DEPTH control, as well.
- **BLEND:** CCW - no effect mixing, 1/2 up - chorus, CW - vibrato.
- **VOL:** Total effect output.

Further Study:

<https://www.diy-stompboxes.com/smforum/index.php?topic=86297.0>

Terms of Use: You are free to use purchased **Florist24** circuit boards for both DIY and small commercial operations. You may not offer **Florist24** PCBs for resale or as part of a "kit" in a commercial fashion. Peer to peer re-sale is fine, though.

Technical assistance for is available via the [madbeanpedals forum](#). Please go there rather than emailing me for personal assistance. This is because (1) I'm not always available to respond via email in a timely and continuous manner, and (2) posting technical problems and solutions in the forum creates a record from which other members may benefit.

All copyrights and registered trademarks are property of their original owners. Any mention of trademarked or intellectual properties in this documents is purely for comparative purposes.

Parts Layout

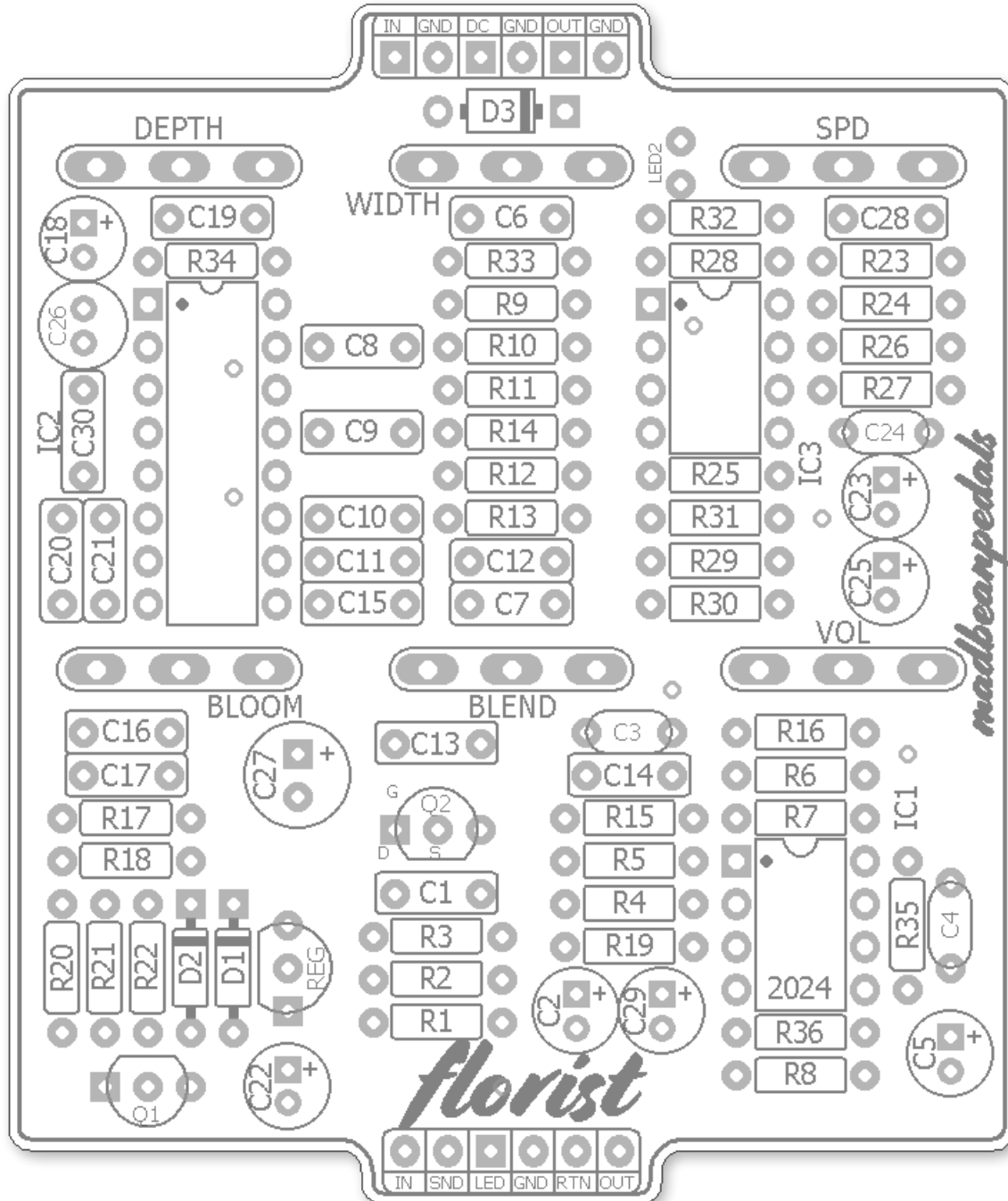

Component Values

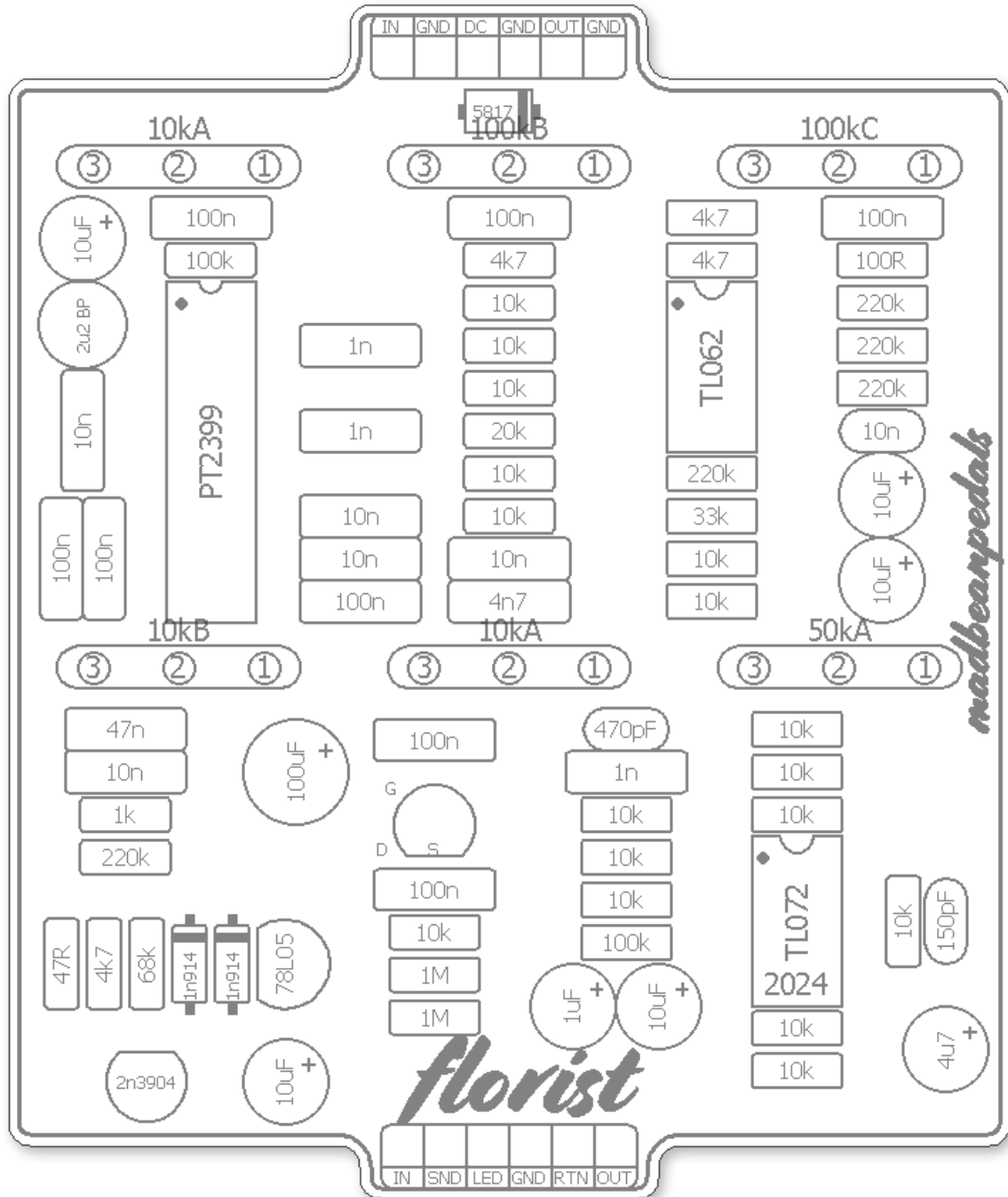

Trace Layout

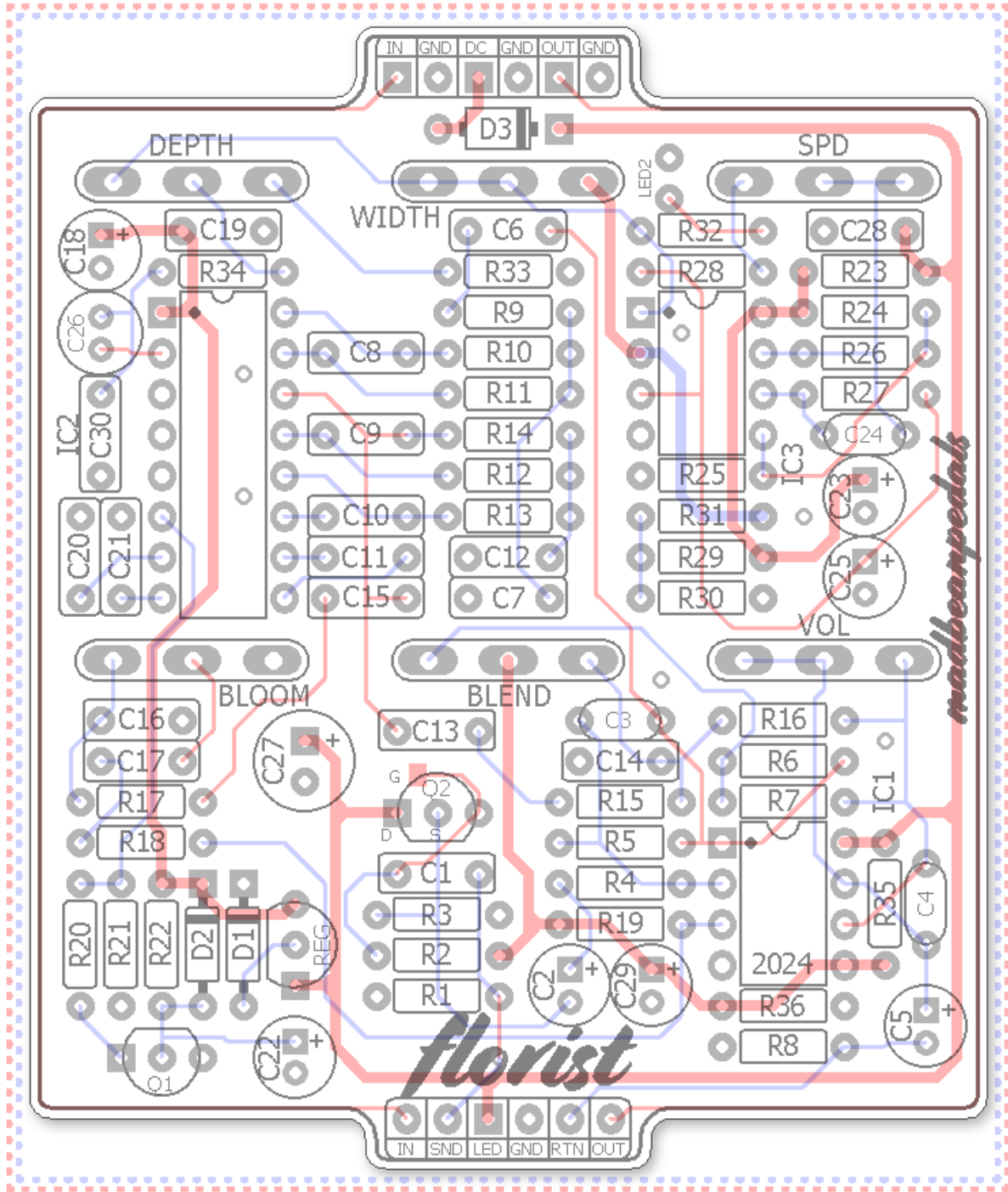

Wiring

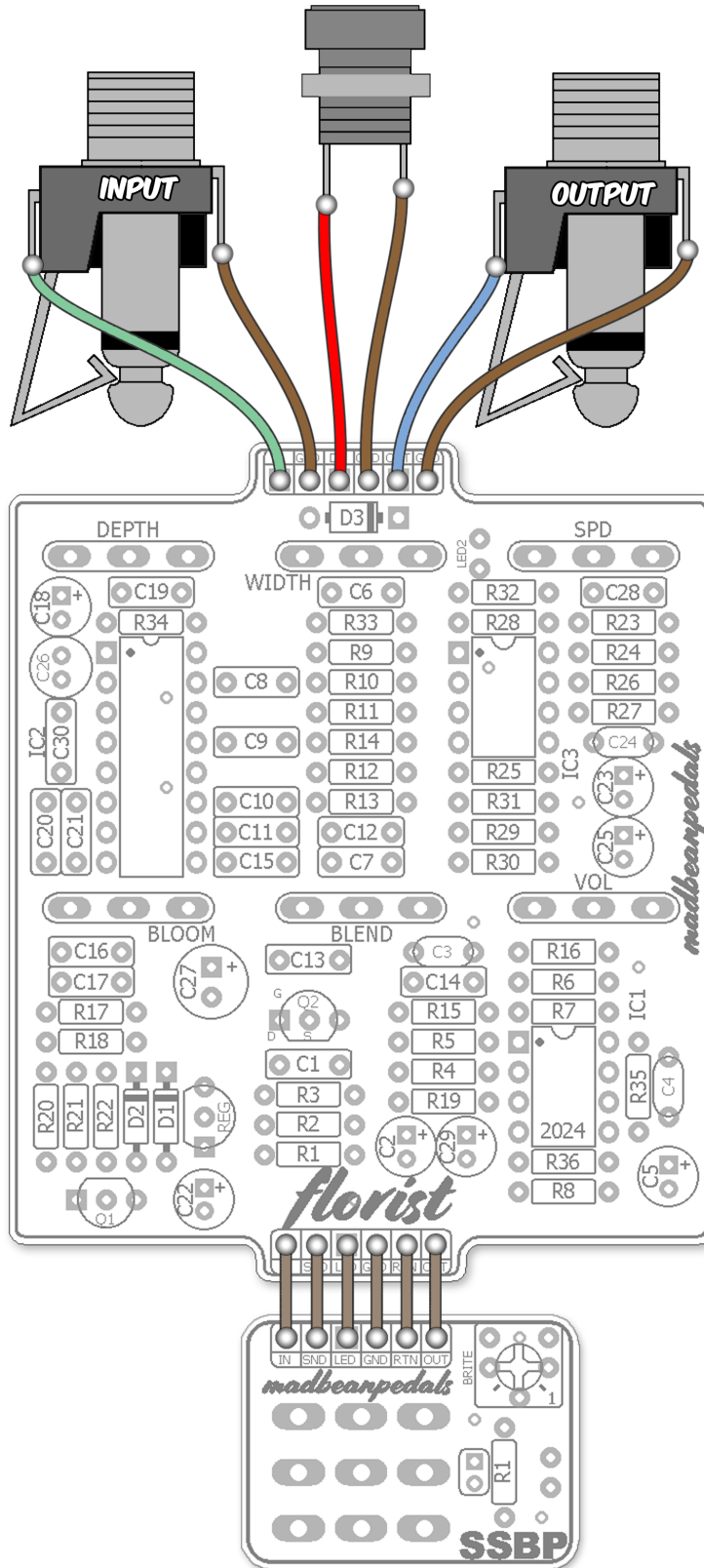

The Florist24 is compatible with both the **SSBP** and **SSABP** bypass boards available at madbeanpedals. The wiring is the same for both.

B.O.M.

Resistors		Caps		Diodes	
R1	1M	C1	100n	D1	1n914
R2	1M	C2	1uF	D2	1n914
R3	10k	C3	470pF	D3	1N5817
R4	10k	C4	150pF	LED2	*any
R5	10k	C5	4u7	Transistors	
R6	10k	C6	100n	Q1	2n3904
R7	10k	C7	4n7	Q2	2N5457
R8	10k	C8	1n	ICs	
R9	10k	C9	1n	IC1	TL072
R10	10k	C10	10n	IC2	PT2399
R11	10k	C11	10n	IC3	TL062
R12	10k	C12	10n	Regulator	
R13	10k	C13	100n	REG	LM78L05
R14	20k	C14	1n	Pots	
R15	10k	C15	100n	BLEND	10kA
R16	10k	C16	47n	DEPTH	10kA
R17	1k	C17	10n	BLOOM	10kB
R18	220k	C18	10uF	VOL	50kA
R19	100k	C19	100n	WIDTH	100kB
R20	47R	C20	100n	SPD	100kC
R21	4k7	C21	100n		
R22	68k	C22	10uF		
R23	100R	C23	10uF		
R24	220k	C24	10n		
R25	220k	C25	10uF		
R26	220k	C26	2u2 BP		
R27	220k	C27	100uF		
R28	4k7	C28	100n		
R29	10k	C29	10uF		
R30	10k	C30	10n		
R31	33k				
R32	4k7				
R33	4k7				
R34	100k				
R35	10k				
R36	10k				

Shopping List

Value	QTY	Type	Rating
47R	1	Metal / Carbon Film	1/4W
100R	1	Metal / Carbon Film	1/4W
1k	1	Metal / Carbon Film	1/4W
4k7	4	Metal / Carbon Film	1/4W
10k	17	Metal / Carbon Film	1/4W
20k	1	Metal / Carbon Film	1/4W
33k	1	Metal / Carbon Film	1/4W
68k	1	Metal / Carbon Film	1/4W
100k	2	Metal / Carbon Film	1/4W
220k	5	Metal / Carbon Film	1/4W
1M	2	Metal / Carbon Film	1/4W
150pF	1	Ceramic / MLCC	16v min.
470pF	1	Ceramic / MLCC	16v min.
1n	3	Film	16v min.
4n7	1	Film	16v min.
10n	6	Film	16v min.
47n	1	Film	16v min.
100n	8	Film	16v min.
2u2 BP	1	Electrolytic, Bi-Polar	16v min.
1uF	1	Electrolytic	16v min.
4u7	1	Electrolytic	16v min.
10uF	5	Electrolytic	16v min.
100uF	1	Electrolytic	16v min.
1n914	1		
1N5817	1		
LED	1	any color	3 or 5mm
2n3904	1		
2N5457	1	or, similar JFET	
TL072	1		
PT2399	1		
TL062	1		
LM78L05	1		
10kA	2	PCB Mount, Right Angle	16mm
10kB	1	PCB Mount, Right Angle	16mm
50kA	1	PCB Mount, Right Angle	16mm
100kB	1	PCB Mount, Right Angle	16mm
100kC	1	PCB Mount, Right Angle	16mm

Additional Hardware

- (1) 125B enclosure
- (2) 1/4" mono jacks
- (1) Slim 2.1mm DC jack
- (1) Standard 3PDT footswitch
- (1) 5mm LED

Build Notes

This build has a lot of parts but should be relatively easy for most DIY'ers. There is nothing to calibrate or trimmers to fool with :) Be sure to solder in your top I/O wires before the WIDTH pot!

LED2 is optional. If you like blinky lights in sync with the LFO then it's there for you. It can be left off without any change to operation of the circuit if you don't.

Mods

- You can increase the max SPD by lowering the value of R28.
- You can increase the max BLOOM by lowering the value of R18. Lower values can enable self-oscillation but this is a less desirable effect because the delay time is so short.
- You can increase/decrease the min DEPTH by changing the value of R33.
- You should be able to sub a 1uF BP or 10uF BP for C26 if you do not have 2u2.
- If you experience any issues with the PT2399 locking up on power up, change R20 from 47R to 100R.

Circuit Voltages

Q2 2N5457		IC2 PT2399		REG LM78L05	
D	9.1	1	5.62	IN	9.11
S	5.01	2	varies	G	0.65
G	4.16	3	0	OUT	5.63
		4	0		
IC1 TL072		5	2.87	Q1 2n3904	
1	4.56	6	0.66	C	202mV
2	4.56	7	0.86	B	0.74
3	4.47	8	0.86	E	0
4	0	9	~2.8		
5	4.56	10	~2.8		
6	4.56	11	~2.8		
7	4.56	12	~2.8		
8	9.1	13	~2.8		
		14	~2.8		
IC3 TL062		15	~2.8		
1	varies	16	~2.8		
2	varies				
3	varies				
4	0				
5	varies				
6	varies				
7	varies				
8	9				

- 9.42vDC One Spot
- Current Draw: ~ 42mA

Drill Template

Coordinates are denoted in **(X,Y)**, **drill size** format starting from the center **(0,0)** location of the enclosure.

Tayda drill template: https://drill.taydakits.com/box-designs/new?public_key=WnZwVnRPeEN3TW1kcjRSNTI6S0tZUT09Cg==

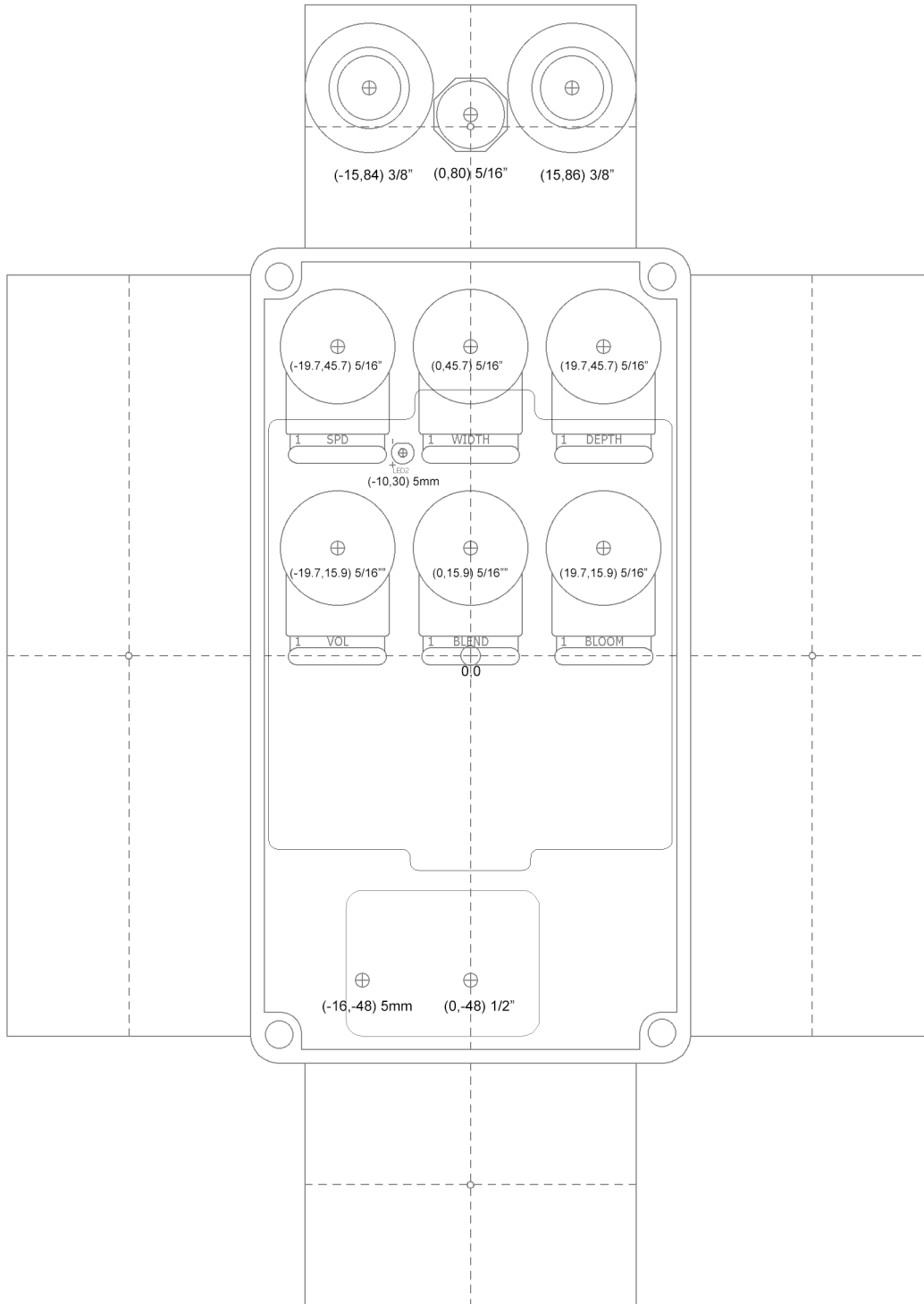

Hardware

125B enclosure
Mono jacks
Slim 2.1mm DC jack
Standard 3PDT footswitch
5mm LED

NOTE: Different 1/4" and DC jack styles may require different sized drill holes.

Build Pic

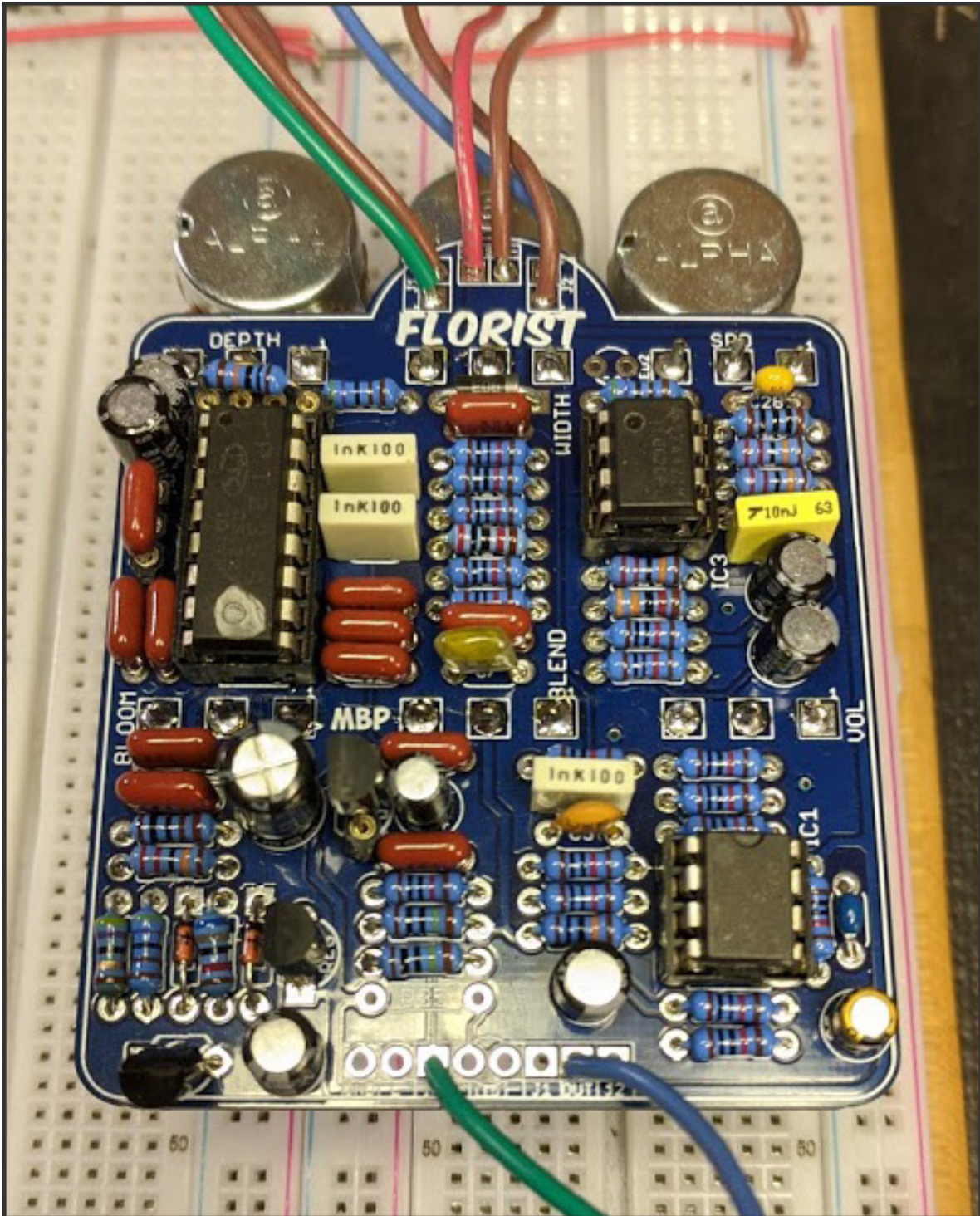

Previous version build

Schematic

THE FLORIST

©2024 madbeanpedals

