

Mysterioso24

FX Type: **OVERDRIVE**
Build Level: Intermediate

Based On: Blackstone Appliances® Mosfet Overdrive™

Last Updated: August 18, 2024 2:25 PM

© 2024 [madbeanpedals](#)



The 2024 version of the **Mysterioso** has no circuit changes and new PCB layout. There is one fix required on this PCB which is detailed in the Notes section.

Overview

As overdrives go, the Blackstone Appliances® Mosfet Overdrive™ has always interested me. Probably because it was the first pedal I traced and it pushed me to get more interested in circuit design. The design itself shares some passing familiarity with other CD4049-based overdrives like the Tube Sound Fuzz (Red Llama), EHX Hot Tubes, ROG Double D and Mark Hammer's Forty-Niner. But it is very much its own thing.

The Mosfet Overdrive™ is a dual channel overdrive derived from a single circuit. Rather than doubling up on the parts, the channel switching is done by swapping between two sets of volume and drive controls, with the tone control being shared. Additionally, channel 1 has two different drive settings: CCW is more mids focused and CCW is fatter. The center position is the point of lowest gain (I don't know of any other overdrive set up like this but I am sure there must be one or two).

The Mysterioso is about 95% of the Mosfet Overdrive. I did include a few tweaks to the design that are my own preference for this effect. These include a tone bypass switch with options and reducing the two internal trimmers to one. Additionally, the stock reactive/buffer switch has been made external. This isn't what I would call a "Plug N Play" type OD. It takes a little bit of tweaking to get it right for your gear and I will explain how to do that in the Notes section, as well as offer some mod suggestions. This is, at its core, a very mids focused overdrive and may not be for everyone. But, I've found some killer tones in it. Just a few months ago I got to play it through a Carr Mercury and it slayed with that amp and a Gibson DC!

Controls

- **GAIN1, VOL1 (Right Side):** This channel is split between two drive settings and what I would call the rhythm channel. For humbucker pickups, turning the GAIN control CCW will slough off some bass. For single coils, setting the GAIN control CW will fatten up the tone. The middle setting in minimal distortion.
- **GAIN2, VOL2 (Left Side):** This channel is more of the lead/boosted channel and has a traditional gain control - turning it CW will increase the overall distortion.
- **TONE:** The tone control looks a bit like a Big Muff style but changes the mid range rather than panning between LP and HP filters. CCW produces a strong mids cut and CW is normal (or slightly elevated) mids.
- **TB:** The Tone Bypass switch defeats the tone control altogether for a fixed filter.
- **REACT/BUFFER:** Right is "reactive" mode which produces the strongest interaction with your guitar volume knob. In this mode you will have greater control of the overall distortion using just the guitar (if you place the Mysterioso first in your signal chain). In the left position, the guitar passes through a JFET buffer before the gain control and is less interactive with the guitar volume. It is also more mid-ranged.
- **DIP:** This 3-position DIP switch give you a few options for tweaking the Mysterioso. It is explained in the Notes section.
- **T1:** This trimmer sets the Min/Mx distortion possible with the two Gain controls. Please see the Notes section for details.

Terms of Use: You are free to use purchased **Mysterioso24** circuit boards for both DIY and small commercial operations. You may not offer **Mysterioso24** PCBs for resale or as part of a "kit" in a commercial fashion. Peer to peer re-sale is fine, though.

Technical assistance for is available via the [madbeanpedals forum](#). Please go there rather than emailing me for personal assistance. This is because (1) I'm not always available to respond via email in a timely and continuous manner, and (2) posting technical problems and solutions in the forum creates a record from which other members may benefit.

All copyrights and registered trademarks are property of their original owners. Any mention of trademarked or intellectual properties in this documents is purely for comparative purposes.

Parts Layout

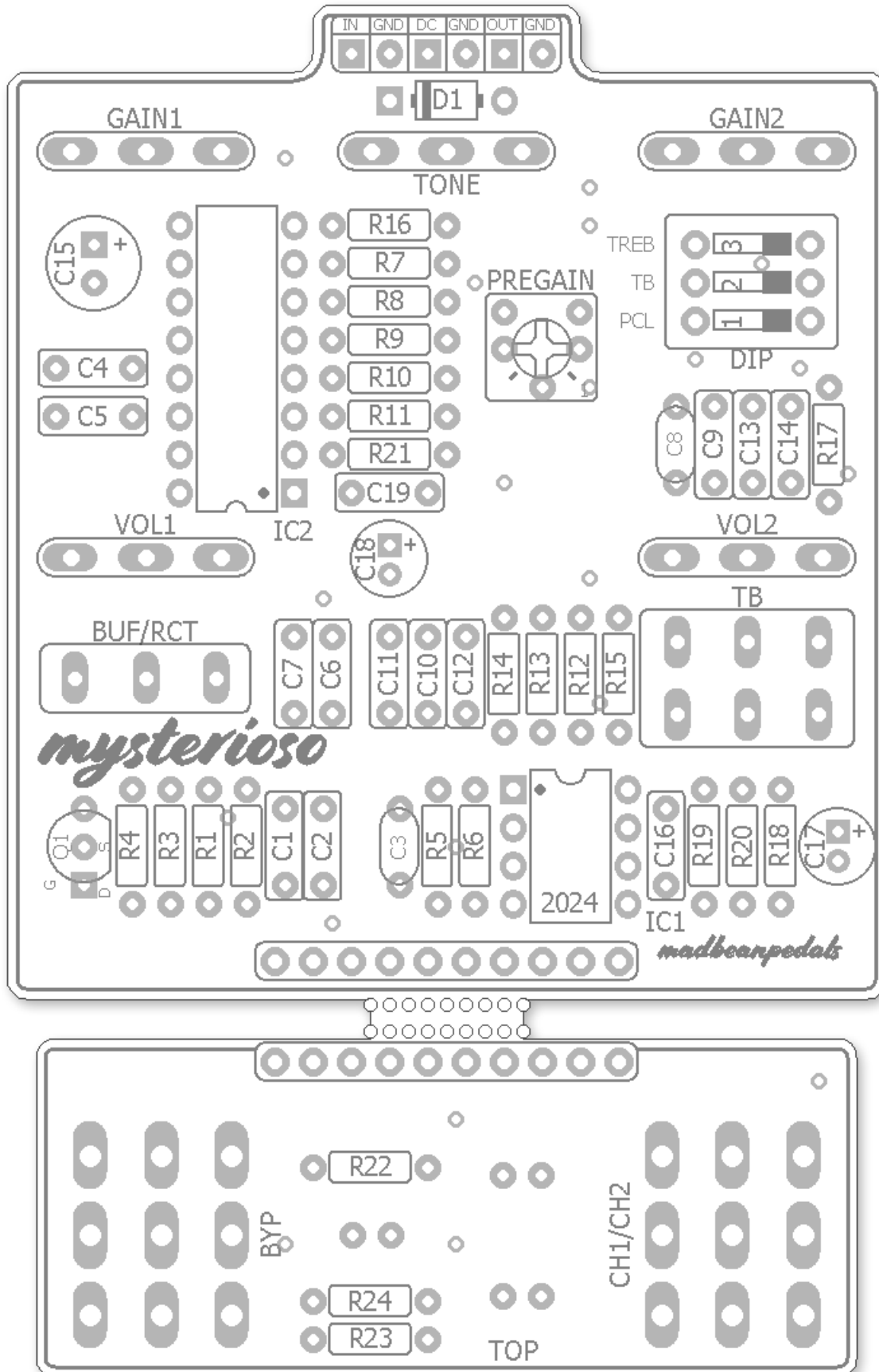

Component Values

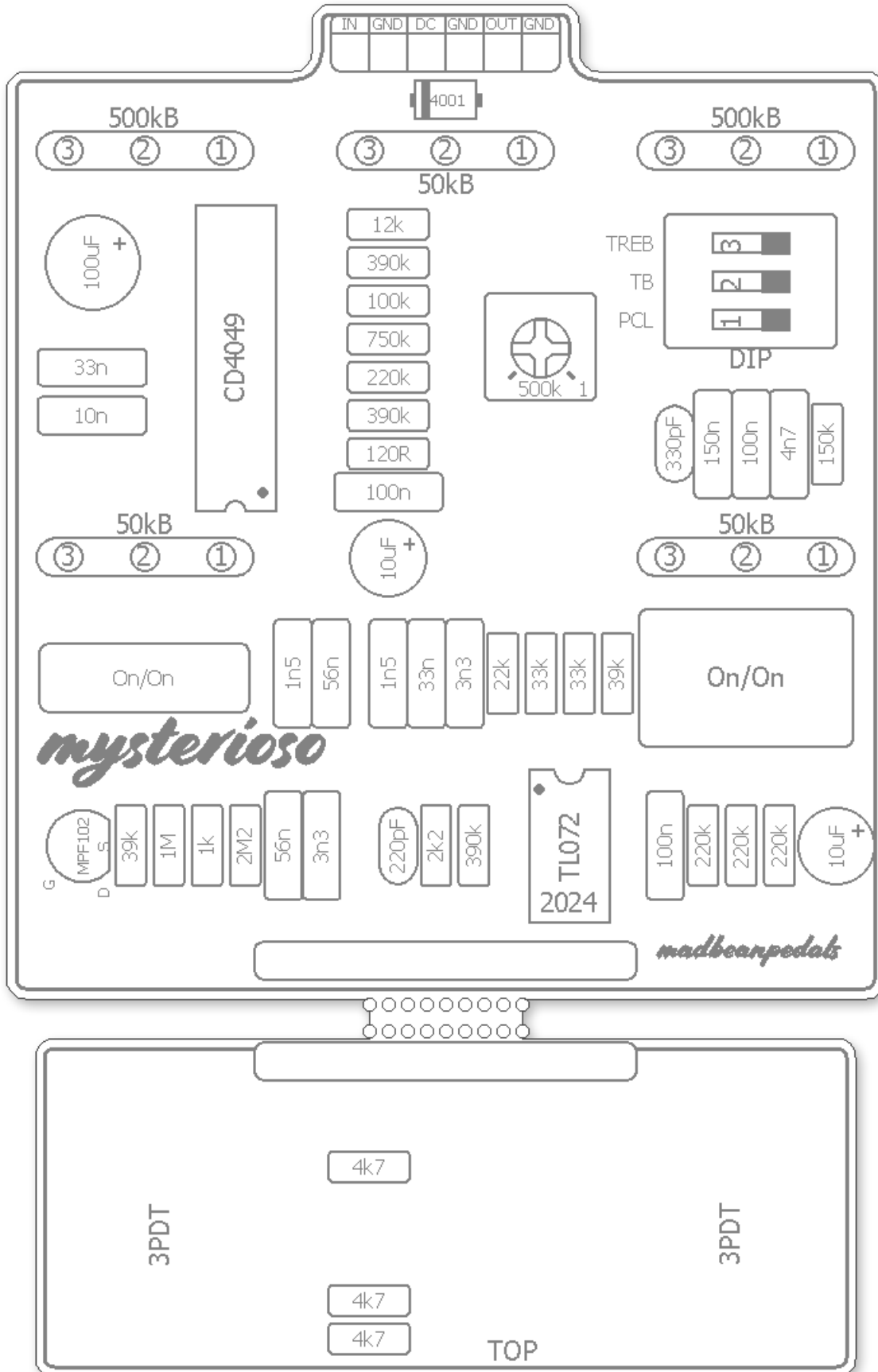

Trace Layout

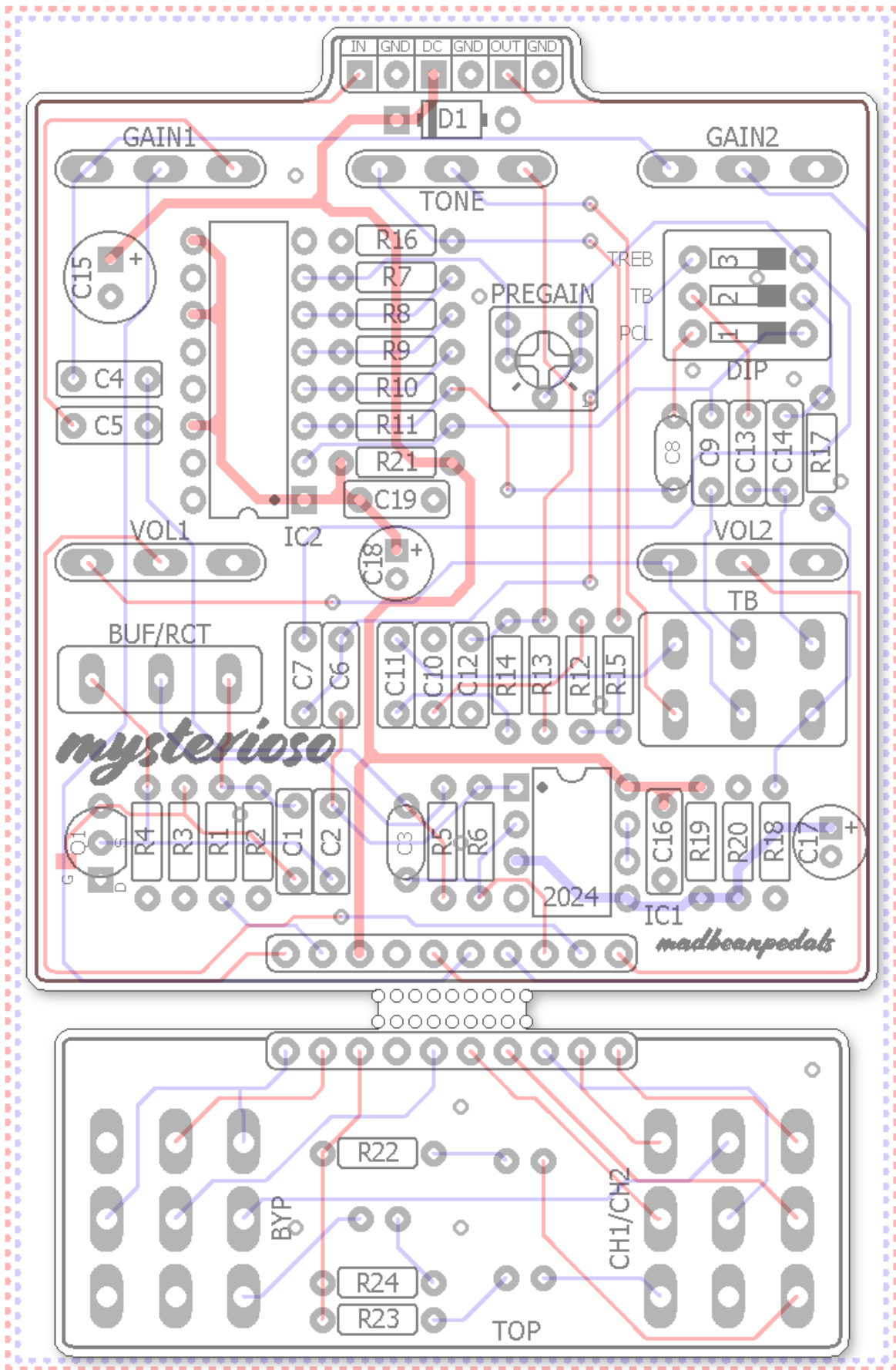

Wiring

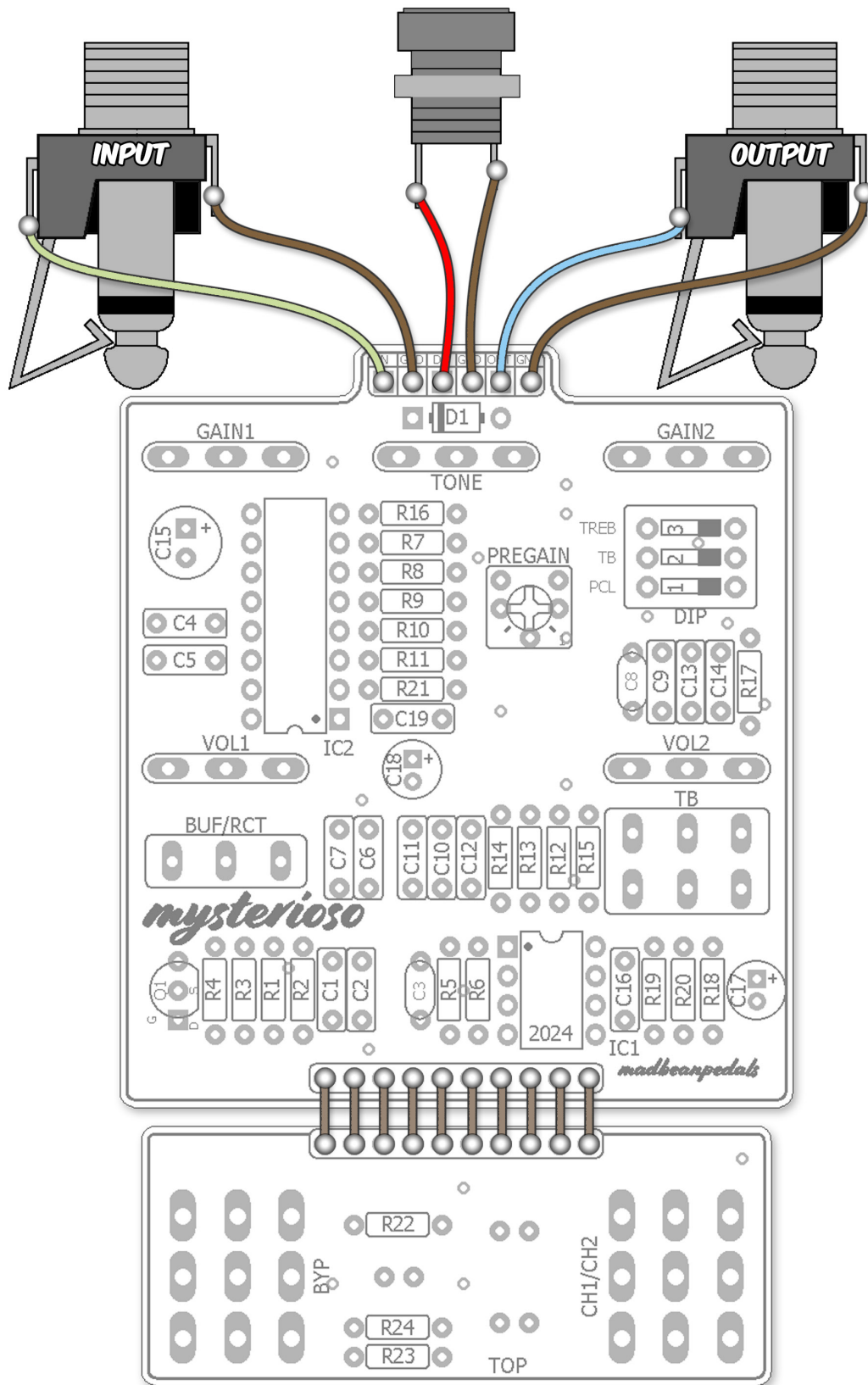

B.O.M.

Resistors		Caps		Diodes	
R1	1k	C1	56n	D1	1N4001
R2	2M2	C2	3n3	LED1	LED
R3	1M	C3	220pF	LED2	LED
R4	39k	C4	33n	LED3	LED
R5	2k2	C5	10n	Transistors	
R6	390k	C6	56n	Q1	MPF102
R7	390k	C7	1n5	ICs	
R8	100k	C8	330pF	IC1	TL072
R9	750k	C9	150n	IC2	CD4049
R10	220k	C10	33n	Switches	
R11	390k	C11	1n5	BUF/RCT	DPDT
R12	33k	C12	3n3	TB	SPDT
R13	33k	C13	100n	CH1/CH2	3PDT
R14	22k	C14	4n7	BYP	3PDT
R15	39k	C15	100uF	DIP	DIP3
R16	12k	C16	100n	Trimmer	
R17	150k	C17	10uF	T1	500k
R18	220k	C18	10uF	Pots	
R19	220k	C19	100n	VOL1	50kB
R20	220k			VOL2	50kB
R21	120R			TONE	50kB
R22	4k7			GAIN1	500kB
R23	4k7			GAIN2	500kB
R24	4k7				

10pin ribbon cable (optional):

<https://stompboxparts.com/cables-wire-plugs/ribbon-cable-10-pin-2/>

3pos. Dip:

<https://stompboxparts.com/dip-switch---3-position/>

Shopping List

Value	QTY	Type	Rating
120R	1	Metal / Carbon Film	1/4W
1k	1	Metal / Carbon Film	1/4W
2k2	1	Metal / Carbon Film	1/4W
4k7	3	Metal / Carbon Film	1/4W
12k	1	Metal / Carbon Film	1/4W
22k	1	Metal / Carbon Film	1/4W
33k	2	Metal / Carbon Film	1/4W
39k	2	Metal / Carbon Film	1/4W
100k	1	Metal / Carbon Film	1/4W
150k	1	Metal / Carbon Film	1/4W
220k	4	Metal / Carbon Film	1/4W
390k	3	Metal / Carbon Film	1/4W
750k	1	Metal / Carbon Film	1/4W
1M	1	Metal / Carbon Film	1/4W
2M2	1	Metal / Carbon Film	1/4W
220pF	1	Ceramic / MLCC	
330pF	1	Ceramic / MLCC	
1n5	2	Film	
3n3	2	Film	
4n7	1	Film	
10n	1	Film	
33n	2	Film	
56n	2	Film	
100n	3	Film	
150n	1	Film	
10uF	2	Electrolytic	
100uF	1	Electrolytic	
1N4001	1		
LED	3	any	5mm
MPF102	1	or, 2n5457, J201	
TL072	1		
CD4049	1		
DPDT	1	On/On	
SPDT	1	On/On	
3PDT	2	footswitch	
DIP	1	3-position	
500k	1	Bourns 3362p or 6mm	
50kB	3	PCB Mount, Right Angle	16mm
500kB	2	PCB Mount, Right Angle	16mm

Additional Hardware

- (1) 125B enclosure
- (2) 1/4" mono jacks
- (1) Slim 2.1mm DC jack

Build Notes

Before you begin, break apart the two PCBs. Use a wire cutter to trim the connecting nubs. I suggest using a bit of sandpaper and gently smooth the edges out, too. These PCBs will be very close to one another when boxed up.

FIX

There is one fix required on the Mysterioso24 PCB. Unfortunately, I left the drain pin on Q1 unconnected which means it has no power. Fixing this is very simple so it wouldn't make sense to throw away a whole batch of PCBs over it. I will correct this on the next run of boards.

To fix the error, solder a wire to the bottom of the PCB between the Q1 drain and IC1 pin8. Follow the illustration below.

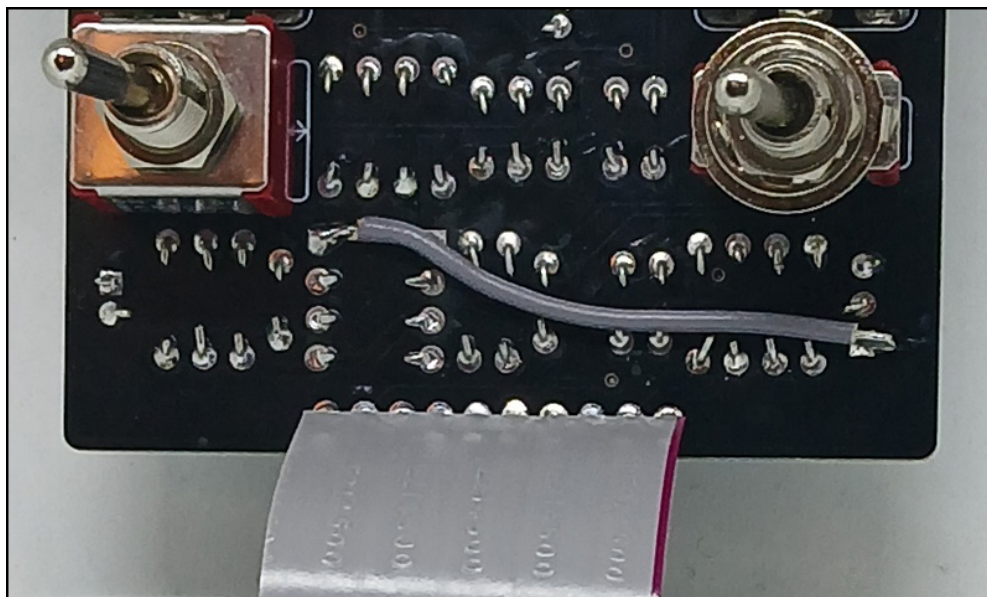
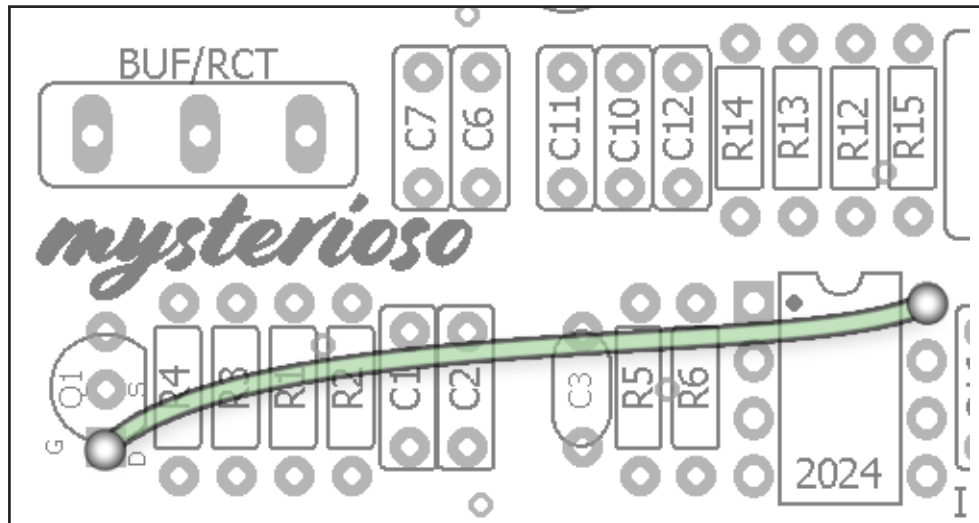

Build Notes

Setup Starting Point

Set Pre-Gain to its midpoint. For the 3-pos. dip switch set the tabs as On, On, Off, top to bottom.

Pre-Gain sets the Min/Max distortion for both the left and right channels. I suggest setting it this way: with the right channel active, put the GAIN1 @ 50%. That is the minimum amount of gain for that channel. Adjust the Pre-Gain trimmer until you have just a bit of breakup. Now check the left channel with GAIN2 at 100%. If you want a bit more distortion, adjust Pre-Gain CCW a bit.

The dip switch enables three different settings

- The first switch is labeled “TREB”. The stock setting is the on position (left). When set to the right pos., a 1n5 cap is added in series with C6. The effect is to add more mids/high end. In the stock design, there were actually two trimmers in parallel. One with the 1n5 cap and one without. They were then adjusted in tandem for balancing low and high frequencies. I never liked this approach, personally, so I chose to remove it. In most cases, you will probably leave the switch on.
- The second switch is “TB” (tone bypass). This enables two different cap values when in Tone Bypass mode. In the on position, the response will be full frequency (more bass). In the off position, the mids are enhanced. You can use different values for C13 and C14 for different tonal shaping.
- The last switch “PCL” stands for Presence Limiting Capacitor. In the on position, a 330pF cap is placed in parallel with the resistor in the last 4049 gain stage to reduce highs. In the original design, this cap was socketed and the manual suggested try different values. The 330pF value actually cuts out quite a bit of high end (starting at around 1230Hz) so this might be a worthwhile area to experiment on. I prefer leaving it off.

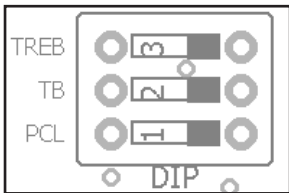

MODS

There are a number of possible mods with the Mysterioso. It is a very mids-focused overdrive and this may not be to everyone's taste. Here are some ideas:

Socket the PLC (C8). The stock 330pF takes off a good bit of top end. Reducing the value will still reduce high end without being quite as drastic. Try 220pF or 180pF.

Socket C2. This is one pretty weird thing in this design. C2 acts as a filter across the entirety of the gain pots and initial gain stage. Without it, the output is unbearably thin. So, my guess is the 3n3 was added as compensation to take off a lot of the excess top end. The result is part of what ends up making the circuit so “middy”. Reducing the value of this cap will reduce some of that mid focus while still removing the thinness you get without it. Suggested values are any of the typical ones between 470pF to 2n2. The right value is a matter of taste.

Double the gain shaping caps. Doubling the values of everything in the initial gain stage will fatten up the whole circuit. So, 22n for 10n (C5), and 56n or 68n for the 33n (C4). Maybe even doubling the 220pF cap up to 470pF. I have not tried this set of mods so YMMV.

Circuit Voltages

IC1	TL072	IC2	CD4049
1	5.02	1	7.98
2	4.68	2	2.96
3	4.65	3	2.95
4	0	4	2.95
5	4.64	5	2.95
6	4.66	6	2.95
7	4.66	7	2.98
8	9.4	8	0
Q1	MPF102	9	7.58
D	9.4	10	ignore
S	3.55	11	4.58
G	0	12	ignore
		13	ignore
		14	7.58
		15	ignore
		16	ignore

- 9.42vDC One Spot
- Current Draw: ~ 20mA

Drill Template

Coordinates are denoted in **(X,Y)**, **drill size** format starting from the center **(0,0)** location of the enclosure.

Tayda drill template: https://drill.taydakits.com/box-designs/new?public_key=bWg2aFpRTTlwQUNWNDI5VIMwV09WUT09Cg==

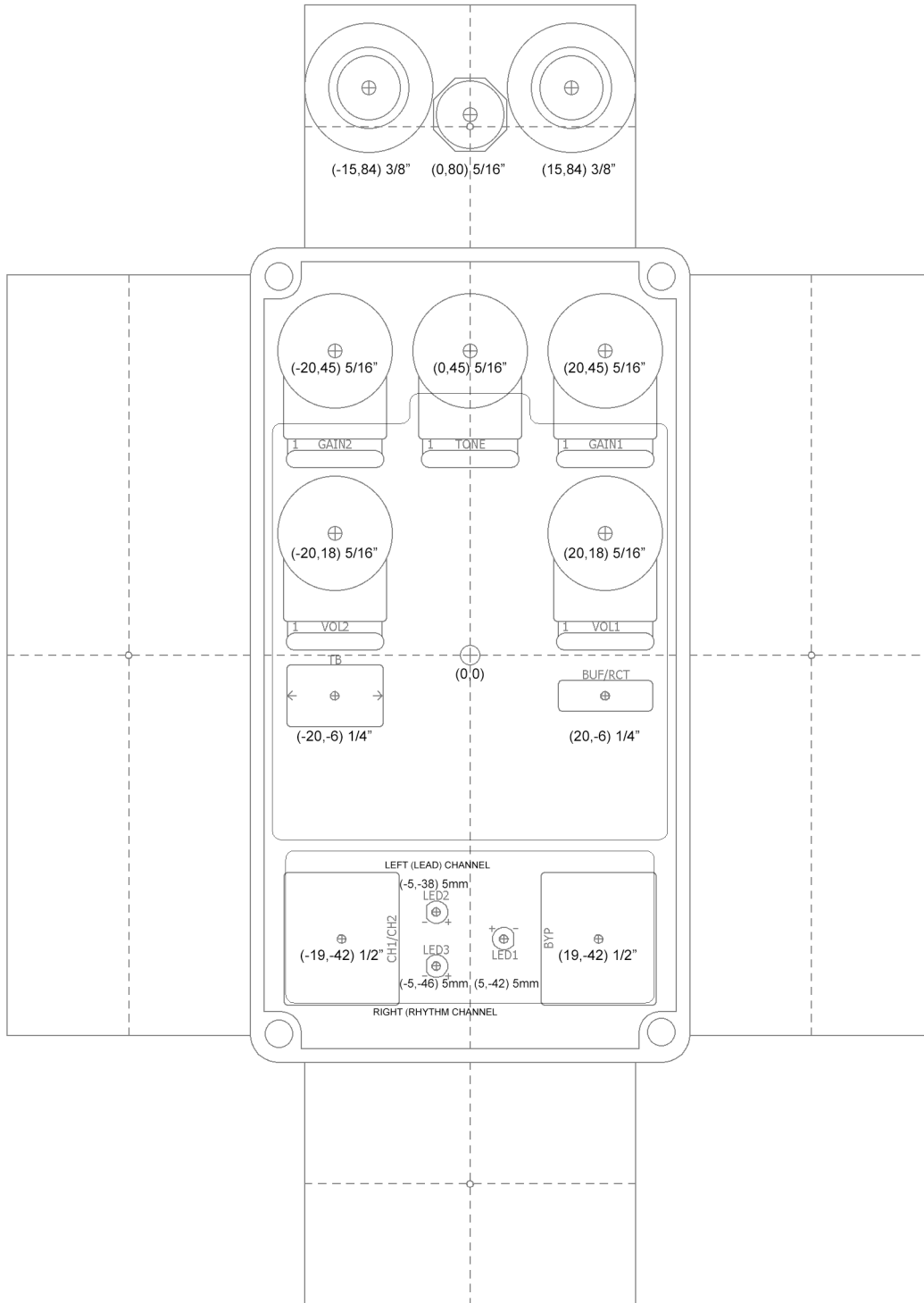

NOTE: Different 1/4\" and DC jack styles may require different sized drill holes.

Build Pic

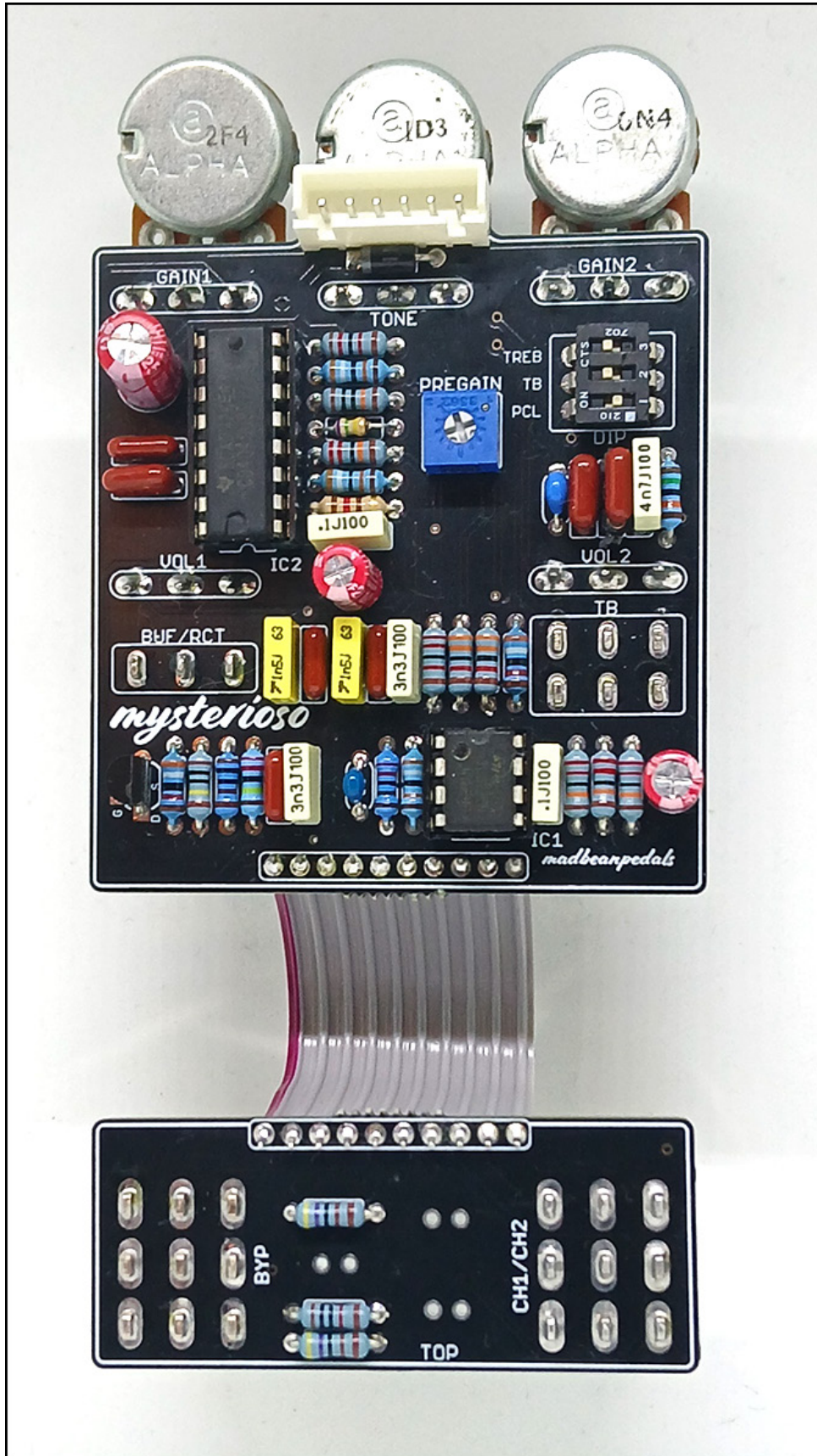

Schematic

