

# Oracle24

**F**X Type: **COMPRESSION**

Build Level: Intermediate

Based On: Boss® CS-3™

Last Updated: August 17, 2024 5:28 PM

© 2024 [madbeanpedals](#)



The 2024 version of the **Oracle** has no circuit changes and minor layout tweaks.

## Overview

The CS-3 has been around for nearly four decades so it doesn't need much introduction. It may be different than other compressor circuits you have seen/built in that it utilizes a high quality Voltage Controlled Amplifier to produce the compression rather than the ubiquitous optical and transistor based ones so prevalent in DIY. The VCA does have it's own sound, in a way. Not as colorful as optical and perhaps not as dynamic as some transistor based compressors. It lives in another place: a very even response compressor with seemingly endless sustain at the highest settings. The addition of the active tone control really helps this one come alive. If you love compression, then I think you'll find this a very worthy addition to your collection.

The original through-hole CS-3 used all SIP op-amps and an older version of the THAT VCA. The Oracle has been converted to DIP op-amps using modern equivalents.

## Controls

- **LVL:** Output level.
- **SUS:** Compression amount.
- **TONE:** Active tone cut/boost.
- **ATTACK:** Controls the amount of picking dynamics present in the compression output from slow to fast response.

Further study: THAT2181 spec page with datasheet and application notes

[http://www.thatcorp.com/2181-series\\_Trimmable\\_Blackmer\\_IC\\_Voltage-Controlled\\_Amplifiers.shtml](http://www.thatcorp.com/2181-series_Trimmable_Blackmer_IC_Voltage-Controlled_Amplifiers.shtml)

**Terms of Use:** You are free to use purchased **Oracle24** circuit boards for both DIY and small commercial operations. You may not offer **Oracle24** PCBs for resale or as part of a "kit" in a commercial fashion. Peer to peer re-sale is fine, though.

**Technical assistance** for is available via the [madbeanpedals forum](#). Please go there rather than emailing me for personal assistance. This is because (1) I'm not always available to respond via email in a timely and continuous manner, and (2) posting technical problems and solutions in the forum creates a record from which other members may benefit.

All copyrights and registered trademarks are property of their original owners. Any mention of trademarked or intellectual properties in this documents is purely for comparative purposes.

# Parts Layout

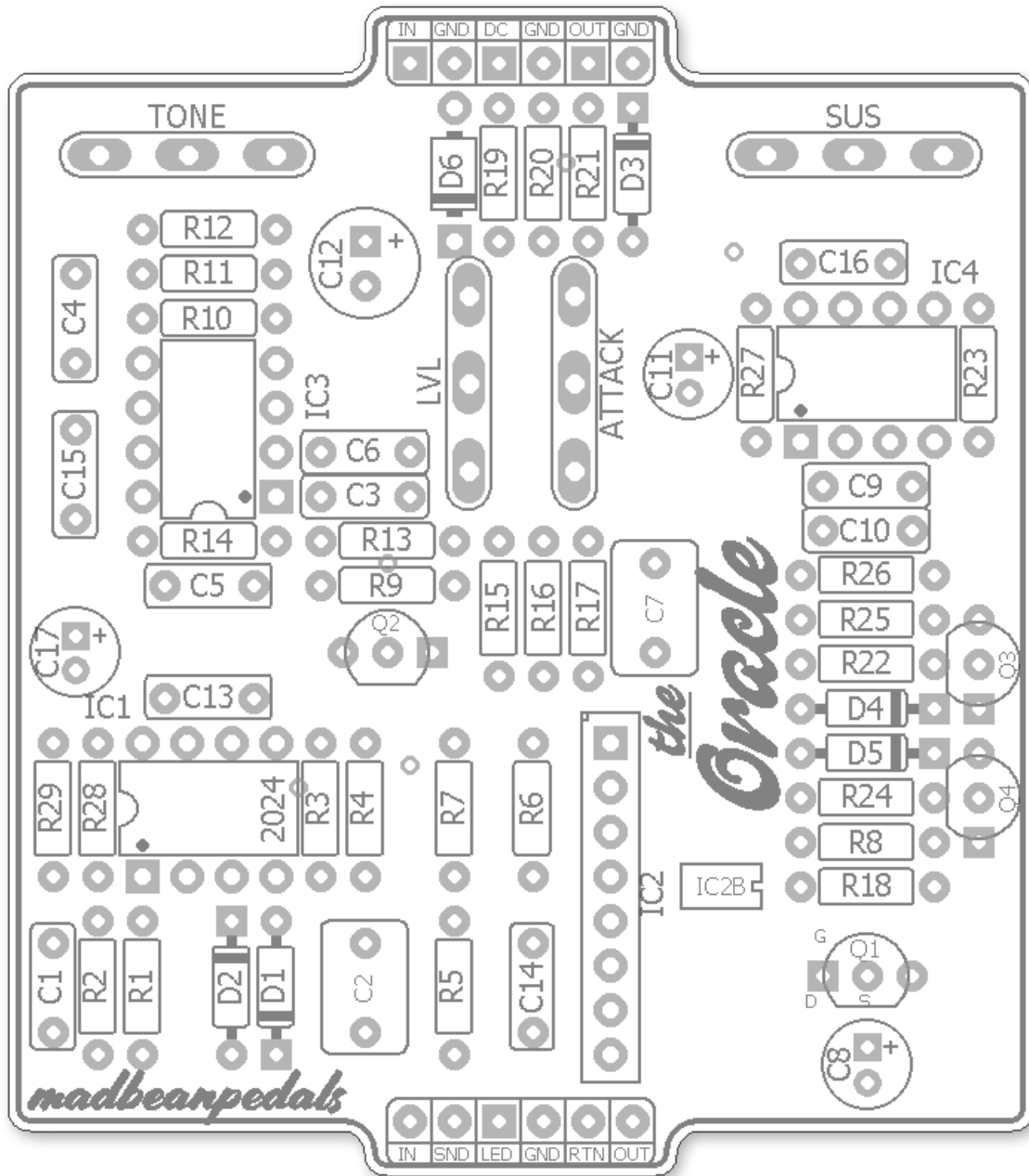



# Trace Layout

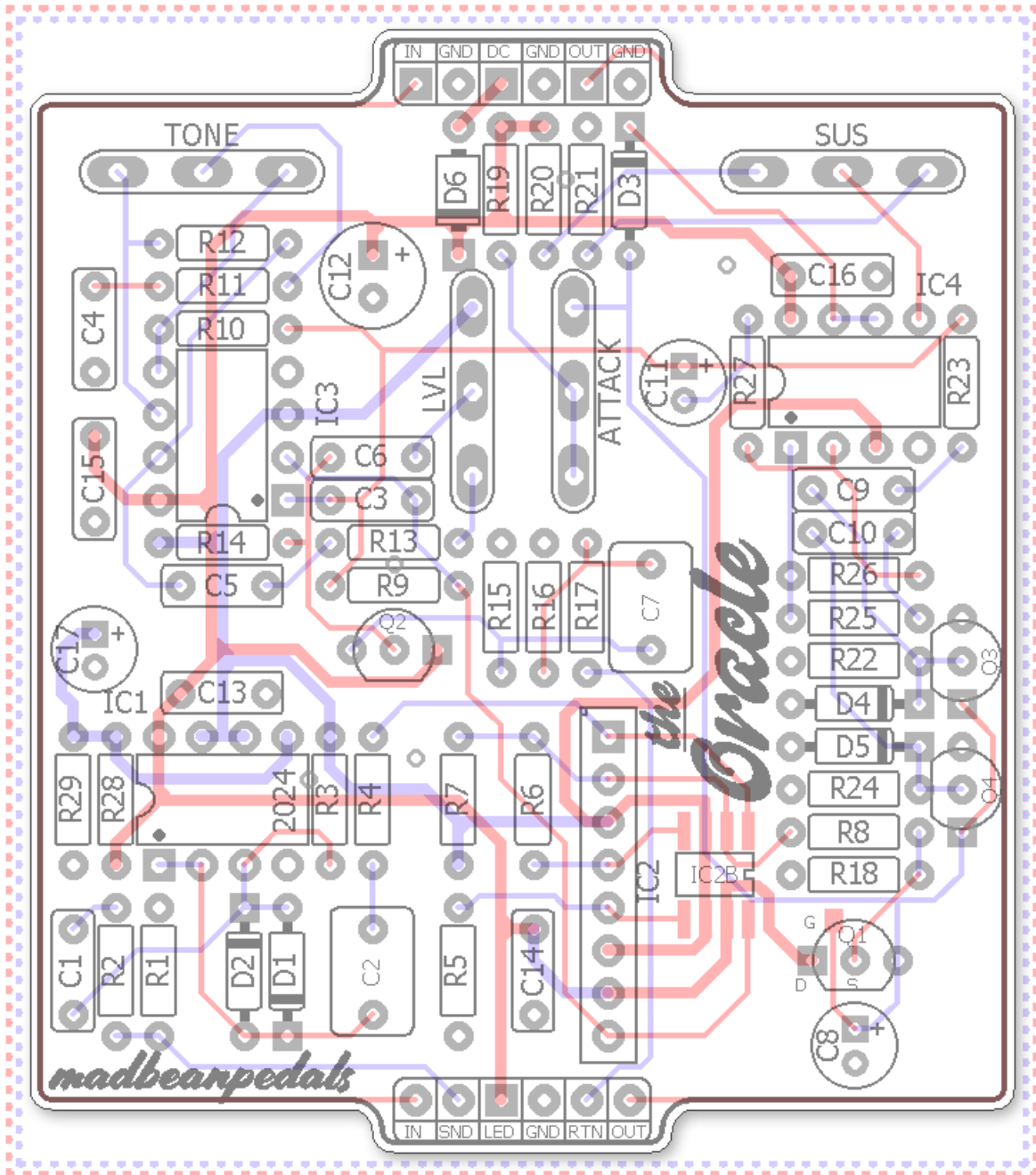

## Wiring

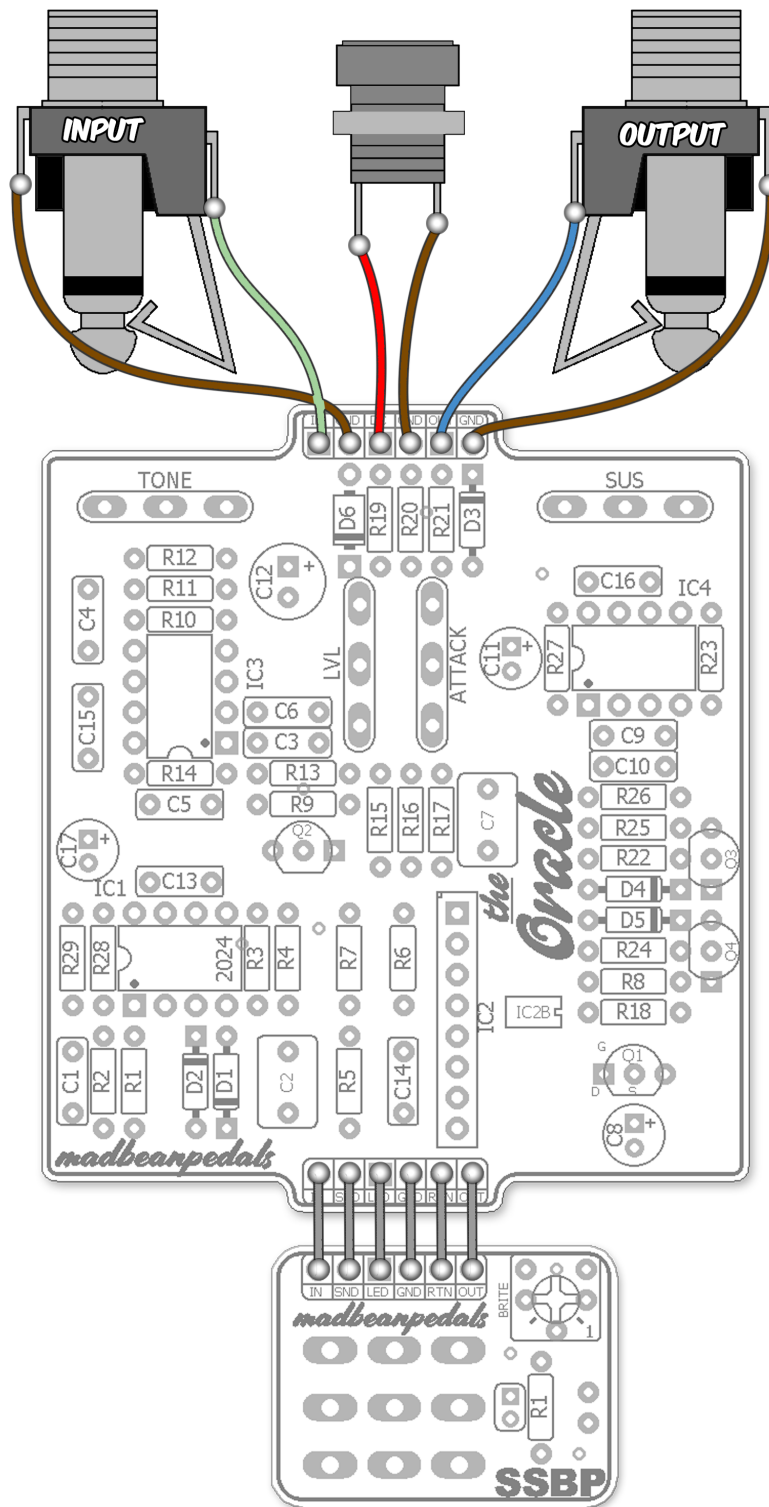

The Oracle24 is compatible with both the **SSBP** and **SSABP** bypass boards available at madbearpedals. The wiring is the same for both.

## B.O.M.

Resistors		Caps		Diodes	
R1	1M	C1	22n	D1	1n914
R2	10k	C2	1uF	D2	1n914
R3	1M	C3	1n8	D3	1n914
R4	10k	C4	27n	D4	1n914
R5	2k7	C5	47n	D5	1n914
R6	47R	C6	47n	D6	1n5817
R7	1k	C7	1uF	Transistors	
R8	15k	C8	4u7	Q1	J201
R9	10k	C9	10n	Q2	2N5088
R10	10k	C10	10n	Q3	2n3904
R11	4k7	C11	1uF	Q4	2n3904
R12	10k	C12	100uF	ICs	
R13	10k	C13	100n	IC1	NE5532
R14	1M	C14	100n	IC2	THAT2181
R15	10k	C15	100n	IC3	NE5532
R16	100k	C16	100n	IC4	NJM2904D
R17	1k	C17	47uF	Pots	
R18	10k			SUS	20kB
R19	22k			TONE	20kB
R20	4k7			LVL	50kA
R21	22k			ATTACK	250kC
R22	1M				
R23	47k				
R24	1M				
R25	47k				
R26	100k				
R27	100k				
R28	10k				
R29	10k				

### NJM2904D:

<https://www.mouser.com/ProductDetail/513-NJM2904D>

(or, sub with comparable op-amp)

### THAT2181 "A":

<https://www.mouser.com/c/semiconductors/audio-ics/audio-amplifiers/?q=2181A>

### THAT2181 "B":

<https://www.mouser.com/c/semiconductors/audio-ics/audio-amplifiers/?q=2181B>

### THAT2181 "C":

<https://www.mouser.com/c/semiconductors/audio-ics/audio-amplifiers/?q=2181C>

### v2181L:

<https://smallbear-electronics.mybigcommerce.com/ic-v2181/>

(I have not tested the Cool Audio version)

## Shopping List

Value	Qty	Type	Rating
47R	1	Metal / Carbon Film	1/4W
1k	2	Metal / Carbon Film	1/4W
2k7	1	Metal / Carbon Film	1/4W
4k7	2	Metal / Carbon Film	1/4W
10k	10	Metal / Carbon Film	1/4W
15k	1	Metal / Carbon Film	1/4W
22k	2	Metal / Carbon Film	1/4W
47k	2	Metal / Carbon Film	1/4W
100k	3	Metal / Carbon Film	1/4W
1M	5	Metal / Carbon Film	1/4W
1n8	1	Film	16v min.
10n	2	Film	16v min.
22n	1	Film	16v min.
27n	1	Film	16v min.
47n	2	Film	16v min.
100n	4	Film	16v min.
1uF	2	Film	16v min.
1uF	1	Electrolytic	16v min.
4u7	1	Electrolytic	16v min.
47uF	1	Electrolytic	16v min.
100uF	1	Electrolytic	16v min.
1n914	5		
1n5817	1		
J201	1	or, MMBFJ201	
2N5088	1		
2n3904	2		
NE5532	2		
THAT2181	1	"B" or "C" suffix	
NJM2904D	1		
20kB	2	PCB Right Angle	16mm
50kA	1	PCB Right Angle	16mm
250kC	1	PCB Right Angle	16mm

### Additional Hardware

- (1) 125B enclosure
- (2) 1/4" mono jacks
- (1) Slim 2.1mm DC jack
- (1) Standard 3PDT footswitch
- (1) 5mm LED

## Build Notes

- There are three varieties of THAT2181 VCA chips. They are labeled with the suffix “A”, “B”, or “C”. “A” indicates lowest THD and highest cost. “B” and “C” increase the THD but at lower cost. I suggest using the C, although the B is certainly fine too. You don’t need the more expensive A version. Also, each of these comes in either SIP or SMD format. I have allowed either version to be used on the Oracle depending on part availability and builder preference.
- Bonus: you can use a SIL socket for the SIP THAT2181. Whichever version you use, make sure you orient pin1 correctly. The surface mount versions sometimes have little white dots to indicate which suffix version they are. Don’t confuse that with the actual pinout!



- Q1 can be either a through-hole or surface mount JFET (J201 is recommended). For surface mount, solder the parts directly over the pads as shown below.

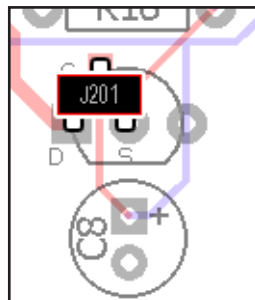



## Circuit Voltages

IC1	NE5532	IC3	NE5532	Q1	J201
1	4.29	1	4.61	D	9.24
2	4.29	2	4.61	S	6.74
3	3.94	3	4.6	G	6.72
4	0	4	0	<b>Q2</b>	<b>2n5088</b>
5	4.6	5	4.6	C	9.24
6	4.6	6	4.6	B	3.7
7	4.6	7	4.61	E	3.38
8	9.24	8	9.24	<b>Q3</b>	<b>2n3904</b>
IC2	THAT2181	IC4	2904D	C	6.74
1	4.6	1	4.6	B	~150mV
2	4.71	2	4.59	E	0
3	4.6	3	4.6	<b>Q4</b>	<b>2n3904</b>
4	4.71	4	0	C	6.74
5	1.8	5	6.25	B	~130mV
6	4.6	6	6.26	E	0
7	9.24	7	6.26		
8	4.61	8	9.24		

- 9.42vDC One Spot
- Current Draw: ~17mA
- Testing Conditions: All knobs about 1/2 up

## Drill Template

Coordinates are denoted in (X,Y), drill size format starting from the center (0,0) location of the enclosure.

Tayda drill template: [https://drill.taydakits.com/box-designs/new?public\\_key=cE1XaFU4ZVFjYWE2dS9RSS9ldVBiZz09Cg==](https://drill.taydakits.com/box-designs/new?public_key=cE1XaFU4ZVFjYWE2dS9RSS9ldVBiZz09Cg==)

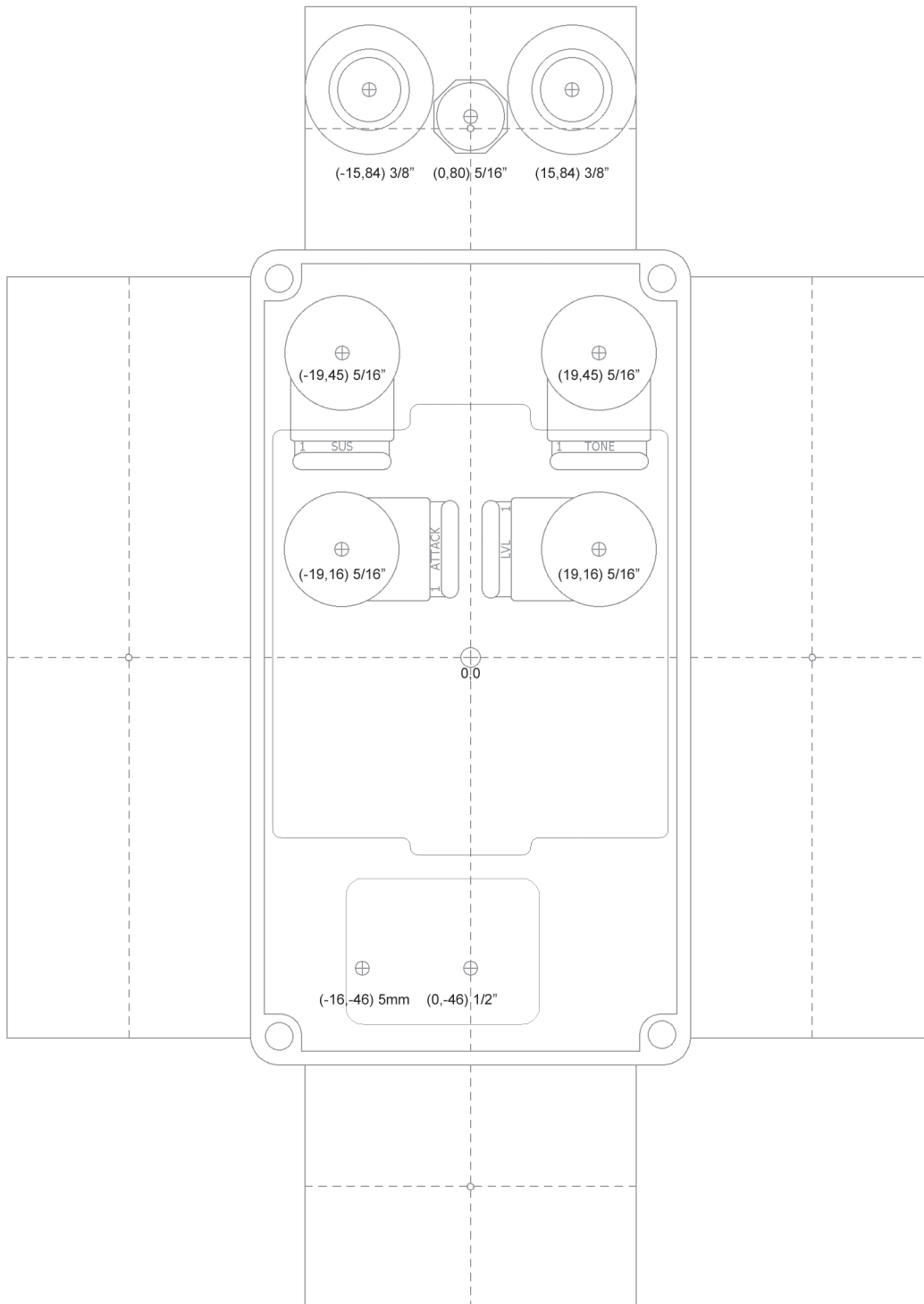

### Hardware

125B enclosure  
Mono jacks  
Slim 2.1mm DC jack  
Standard 3PDT footswitch  
5mm LED

**NOTE: Different 1/4\" and DC jack styles may require different sized drill holes.**

**Build Pic**



Previous version build

# Schematic

