

BoomBoom24

FX Type: **BASS FUZZ / OCTAVER**
Build Level: Intermediate
Based On: Maestro® Brassmaster™

Last Updated: November 20, 2024 3:40 PM
© 2024 [madbeanpedals](#)



The 2024 version of the **BoomBoom** has no significant circuit changes and minor layout tweaks.

Overview

The Brassmaster had a short production life (around 3-4 years) way back in the 70's. It's one of those pedals that has passed into some kind of mythology because of its rareness. But, there are good reasons to warrant the hype. It delivers that special kind of "highly compressed wall of fuzz" that you can really dig into. And, those units seem to go for four figures nowadays. Build one for 1/50th the price!

The **BoomBoom** is a 95% Brassmaster. It uses a more widely available transformer than the vintage unit (but similar spec) and it adds an output volume control.

Controls

- **BASS:** Sets the volume of clean bass sent to the output.
- **SENSE:** Sets the input volume to the octaver/EQ circuit.:
- **BRASS:** Set the output volume of the octaver/EQ circuit.
- **VOL:** The total mixed output from the BASS, SENSE and BRASS controls.
- **HARM:** In the left position, this switch adds some extra octave up signal in parallel with the EQ circuit. In the right position, it sends the full octave up directly to the EQ.
- **BRASS1/2:** This switch toggles between two EQ settings. The left position is mids-focused and the right position is mids-scooped.

See the Notes section for a little more info on using the controls.

Terms of Use: You are free to use purchased **BoomBoom24** circuit boards for both DIY and small commercial operations. You may not offer **BoomBoom24** PCBs for resale or as part of a "kit" in a commercial fashion. Peer to peer re-sale is fine, though.

Technical assistance for is available via the [madbeanpedals forum](#). Please go there rather than emailing me for personal assistance. This is because (1) I'm not always available to respond via email in a timely and continuous manner, and (2) posting technical problems and solutions in the forum creates a record from which other members may benefit.

All copyrights and registered trademarks are property of their original owners. Any mention of trademarked or intellectual properties in this documents is purely for comparative purposes.

Parts Layout

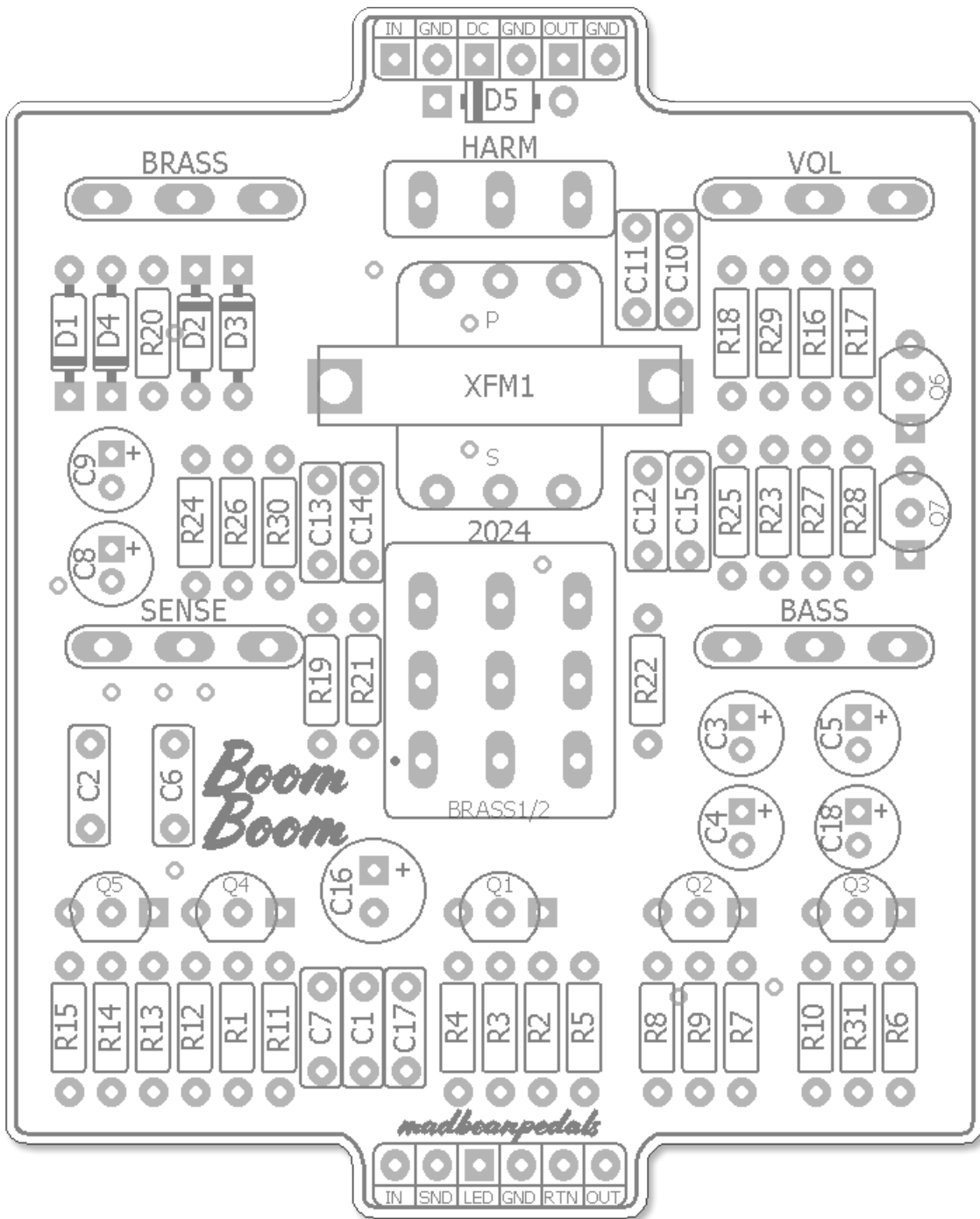

Component Values

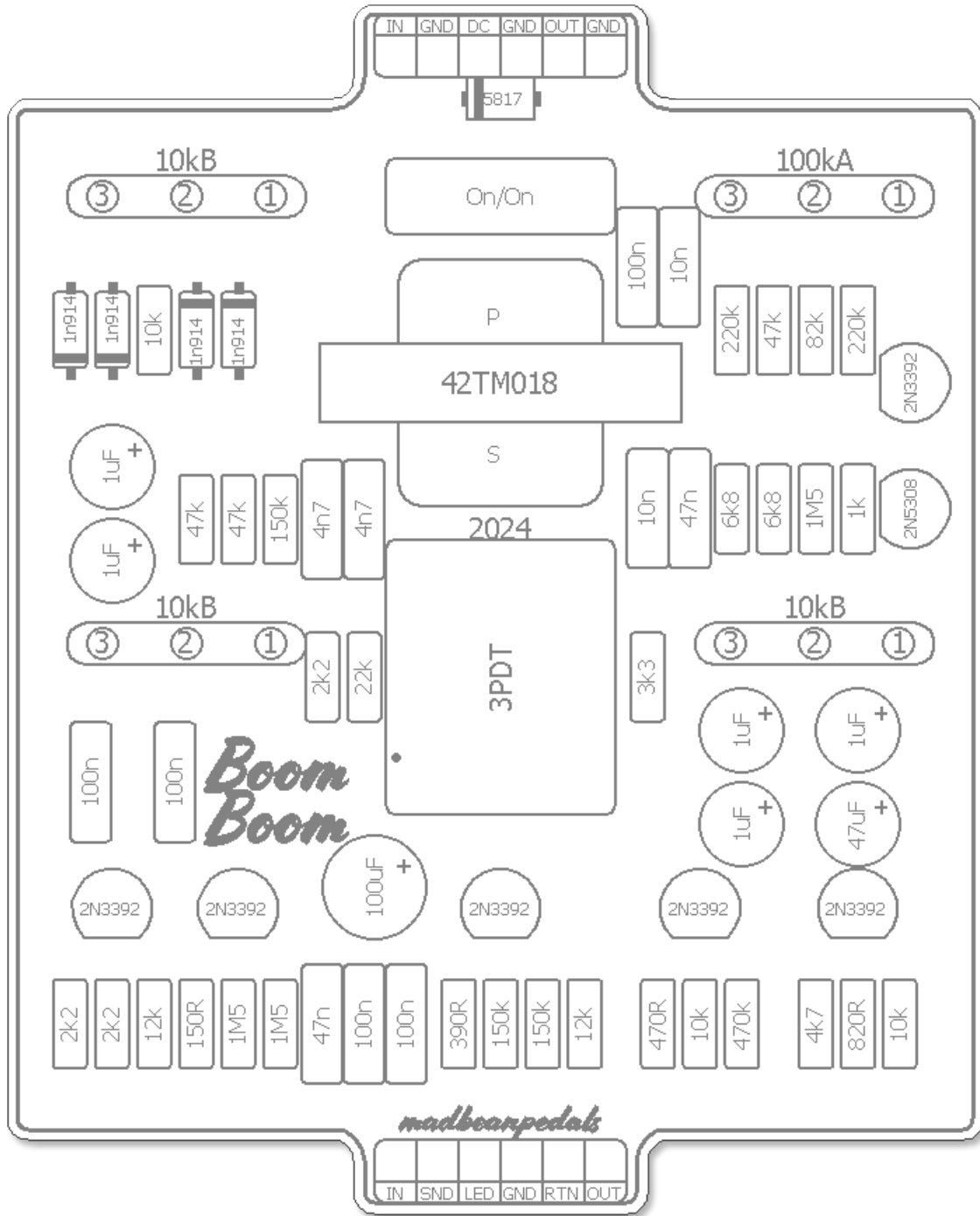

Trace Layout

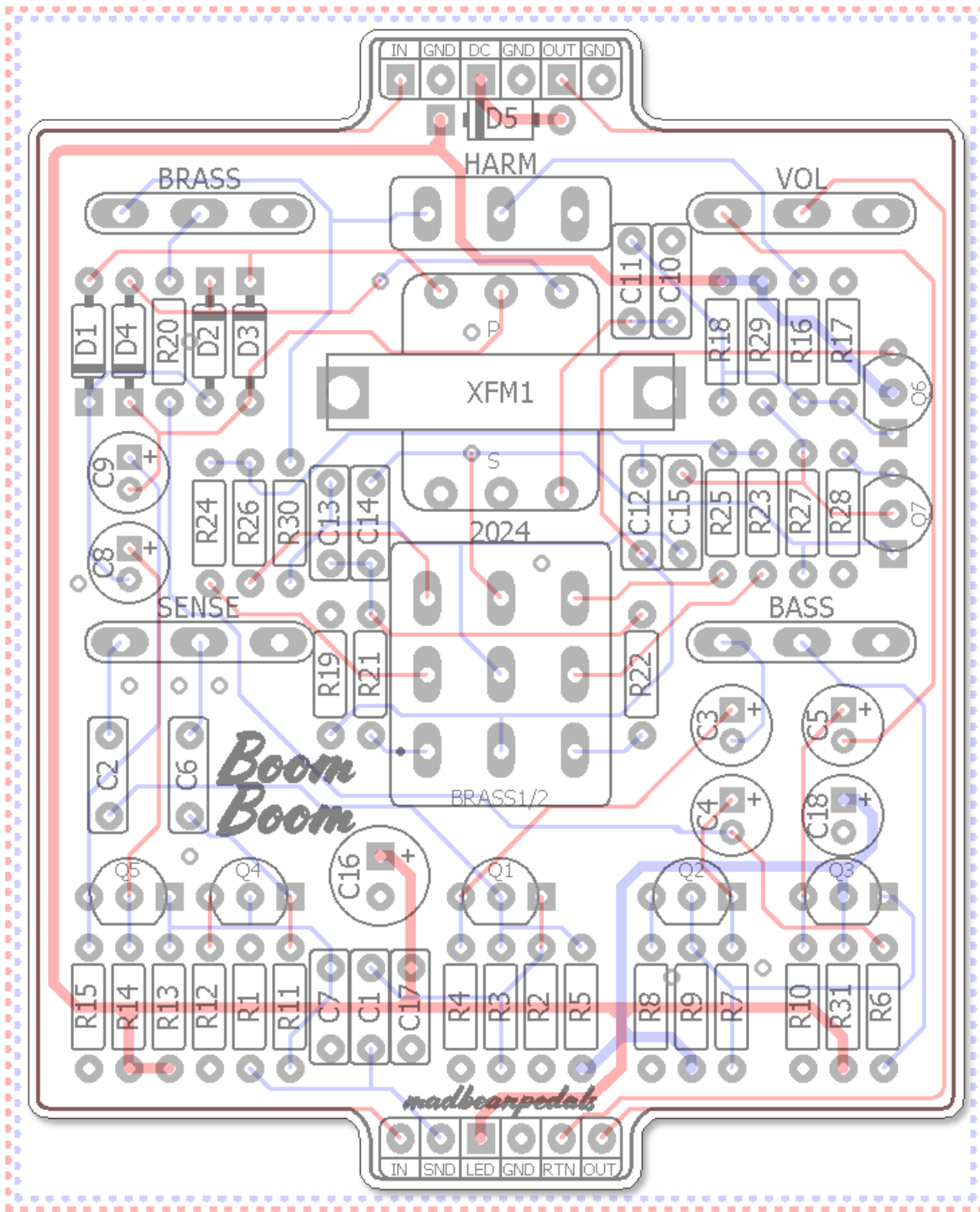

Wiring

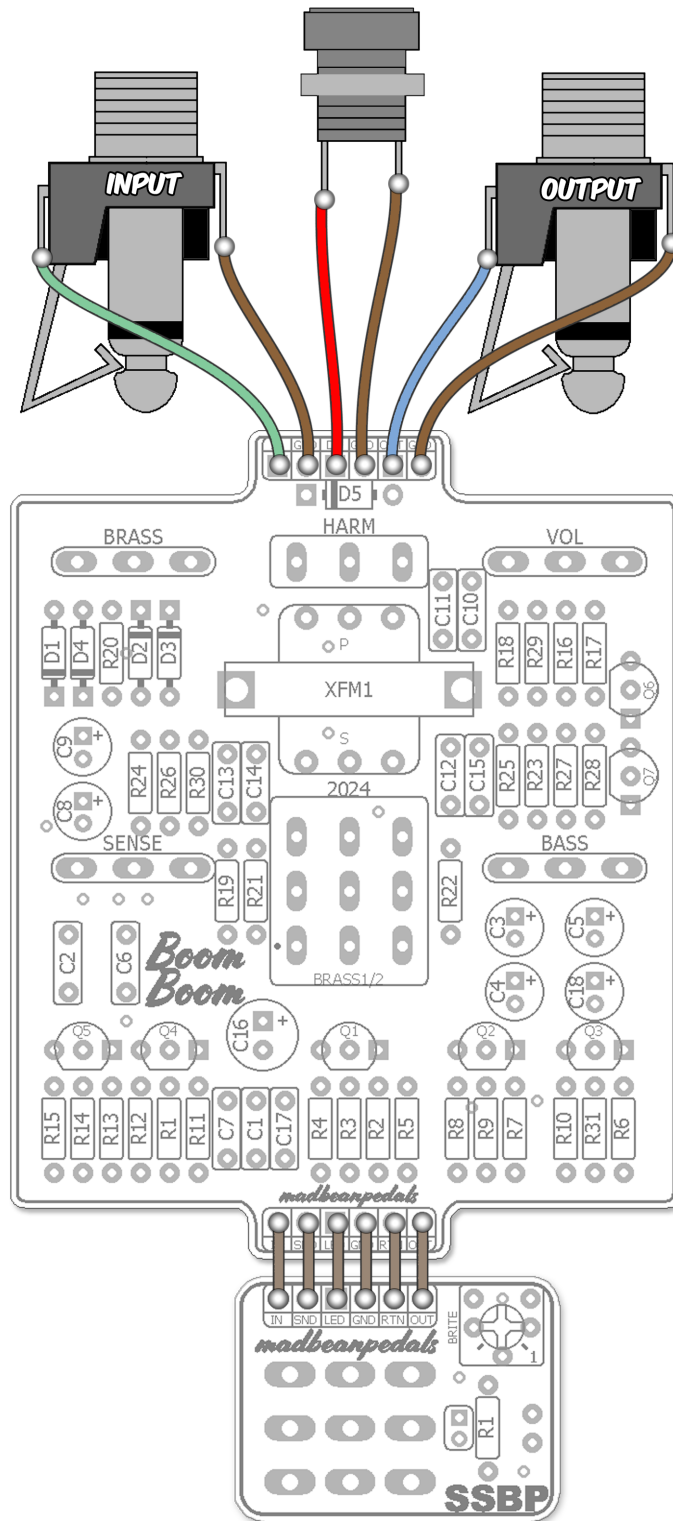

The BoomBoom24 is compatible with both the **SSBP** and **SSABP** bypass boards available at madbeanpedals. The wiring is the same for both.

B.O.M.

Resistors		Caps		Diodes	
R1	1M5	C1	100n	D1	1n914
R2	150k	C2	100n	D2	1n914
R3	150k	C3	1uF	D3	1n914
R4	390R	C4	1uF	D4	1n914
R5	12k	C5	1uF	D5	1N5817
R6	10k	C6	100n	Transistors	
R7	470k	C7	47n	Q1	2N3392
R8	470R	C8	1uF	Q2	2N3392
R9	10k	C9	1uF	Q3	2N3392
R10	4k7	C10	10n	Q4	2N3392
R11	1M5	C11	100n	Q5	2N3392
R12	150R	C12	10n	Q6	2N3392
R13	12k	C13	4n7	Q7	2N5308
R14	2k2	C14	4n7	Transformer	
R15	2k2	C15	47n	XFM1	42TM018
R16	82k	C16	100uF	Switches	
R17	220k	C17	100n	HARM	SPDT
R18	220k	C18	47uF	BRASS1/2	3PDT
R19	2k2	Pots			
R20	10k			BASS	10kB
R21	22k			BRASS	10kB
R22	3k3			SENSE	10kB
R23	6k8			VOL	100kA
R24	47k				
R25	6k8				
R26	47k				
R27	1M5				
R28	1k				
R29	47k				
R30	150k				
R31	820R				

2n3392:

<http://smallbear-electronics.mybigcommerce.com/transistor-2n3392/>

2n5308:

<http://smallbear-electronics.mybigcommerce.com/transistor-2n5308/>

42TM018:

<https://www.mouser.com/ProductDetail/42TM018-RC>

Shopping List

Values	QTY	Type	Rating
150R	1	Metal / Carbon Film	1/4W
390R	1	Metal / Carbon Film	1/4W
470R	1	Metal / Carbon Film	1/4W
820R	1	Metal / Carbon Film	1/4W
1k	1	Metal / Carbon Film	1/4W
2k2	3	Metal / Carbon Film	1/4W
3k3	1	Metal / Carbon Film	1/4W
4k7	1	Metal / Carbon Film	1/4W
6k8	2	Metal / Carbon Film	1/4W
10k	3	Metal / Carbon Film	1/4W
12k	2	Metal / Carbon Film	1/4W
22k	1	Metal / Carbon Film	1/4W
47k	3	Metal / Carbon Film	1/4W
82k	1	Metal / Carbon Film	1/4W
150k	3	Metal / Carbon Film	1/4W
220k	2	Metal / Carbon Film	1/4W
470k	1	Metal / Carbon Film	1/4W
1M5	3	Metal / Carbon Film	1/4W
4n7	2	Film	16v min.
10n	2	Film	16v min.
47n	2	Film	16v min.
100n	5	Film	16v min.
1uF	5	Electrolytic	16v min.
47uF	1	Electrolytic	16v min.
100uF	1	Electrolytic	16v min.
1n914	4		
1N5817	1		
2N3392	6	NPN	
2N5308	1	NPN	
42TM018	1	10KCT-10KCT transformer	
SPDT	1	On/On, Solder Lug	
3PDT	1	On/On, Solder Lug	
10kB	3	PCB Right Angle	16mm
100kA	1	PCB Right Angle	16mm

Additional Hardware

- (1) 125B enclosure
- (2) 1/4" mono jacks
- (1) Slim 2.1mm DC jack
- (1) Standard 3PDT footswitch
- (1) 5mm LED

Build Notes

The best way to understand how the four potentiometer controls work is to simply think of them as volume or mix controls. IOW, what you get at the output is due to a combination of mixed signal levels.

To get output at the BRASS pot, you'll need to have some signal going in from the SENSE pot. The more SENSE you have, the more aggressive the BRASS control will be. To add some extra bottom end, turn up the cleans with the BASS control. And, so on. The added VOL pot makes balancing these mixed signals easier, IMO, and seems to be a popular mod for DIY versions of this circuit.

Use the Build Pic (2nd to last page) to see the transistor orientation. The 2n3392 are kind of neat with their oval, smooth packaging.

Make sure you put the transformer in the right way! The PCB has labels for Primary and Secondary (P and S).

Circuit Voltages

Q1	2n3392	Q4	2n3392	Q7	2n5308
B	0.77	B	0.64	B	0.95
C	2.05	C	4.7	C	7.4
E	193mV	E	55mV	E	33mV

Q2	2n3392	Q5	2n3392
B	0.85	B	4.7
C	2.5	C	5.2
E	260mV	E	4

Q3	2n3392	Q6	2n3392
B	2.5	B	1.94
C	8	C	9.17
E	1.9	E	1.35

- 9.42vDC One Spot
- Current Draw ~ 5mA

Drill Template

Coordinates are denoted in **(X,Y)**, **drill size** format starting from the center (0,0) location of the enclosure.

Tayda drill template: https://drill.taydakits.com/box-designs/new?public_key=aWFBYVhIWC9MaTE3dXINZUNTU0huUT09Cg==

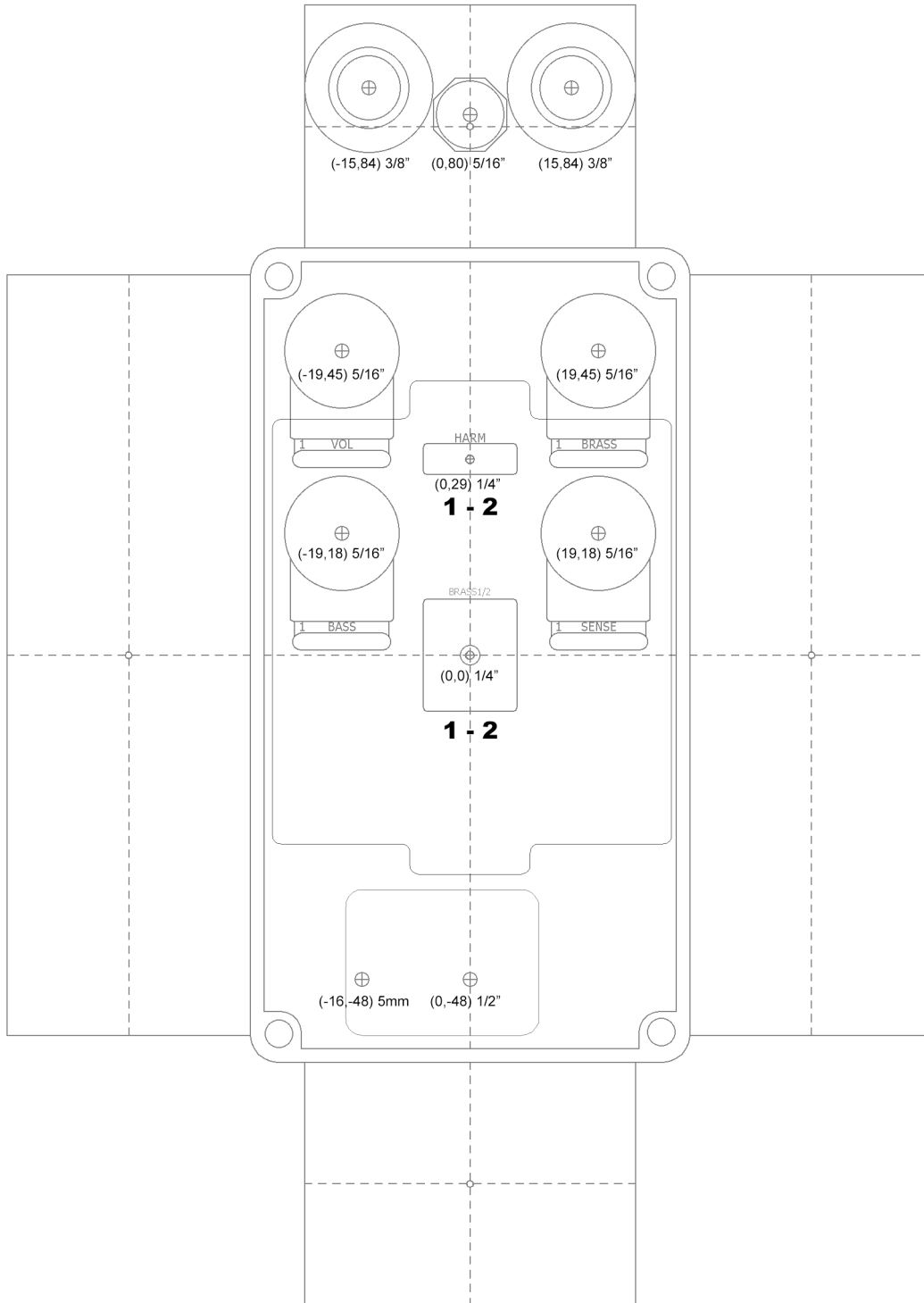

Hardware

125B enclosure
Mono jacks
Slim 2.1mm DC jack
Standard 3PDT footswitch
5mm LED

NOTE: Different 1/4" and DC jack styles may require different sized drill holes.

Build Pic

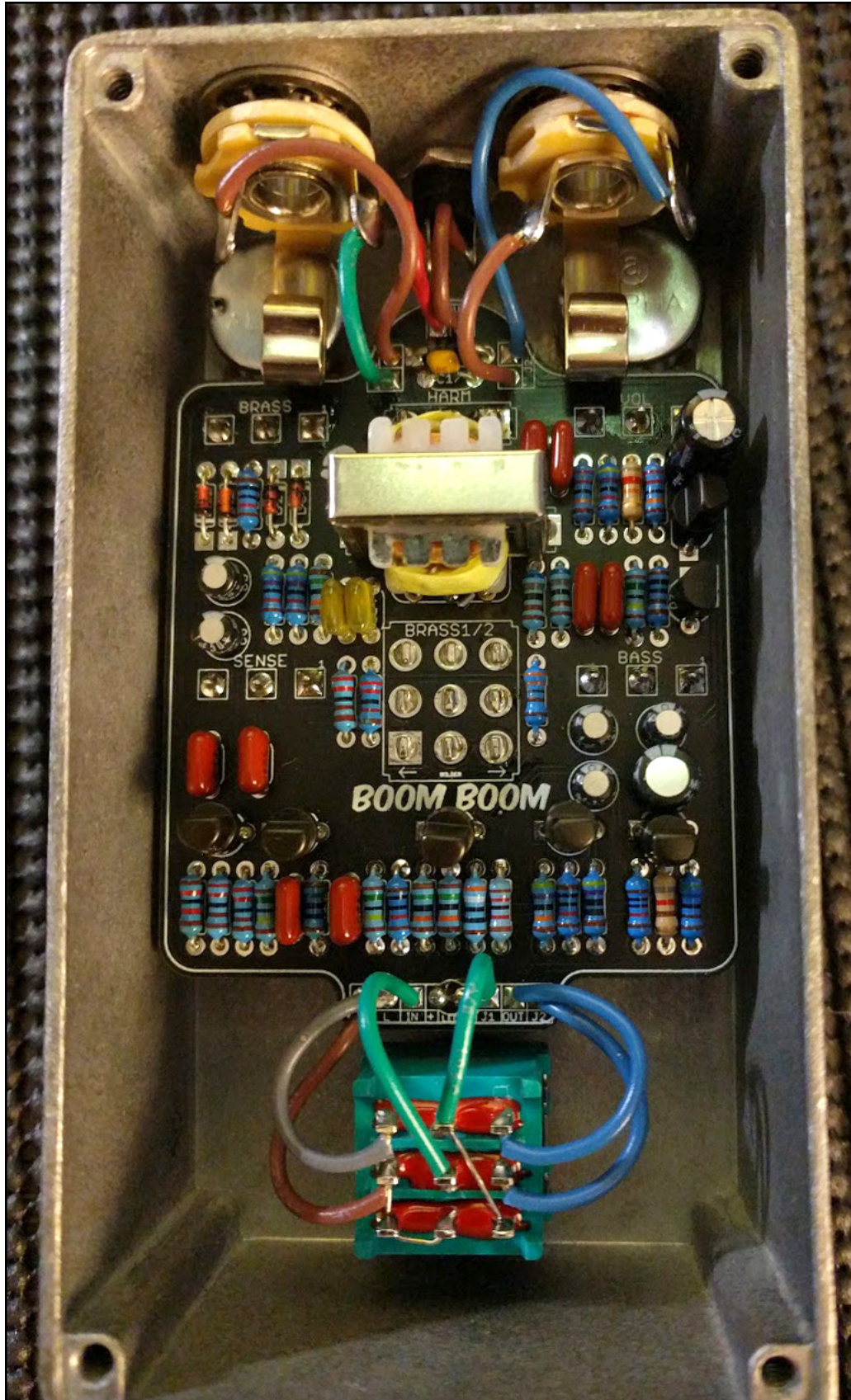

Previous version build.

Schematic

