

KINGSLAYER

2015 edition © madbeanpedals

FX Type: **Overdrive**

Based on the Klon Centaur™

2.05" W x 2.375" H

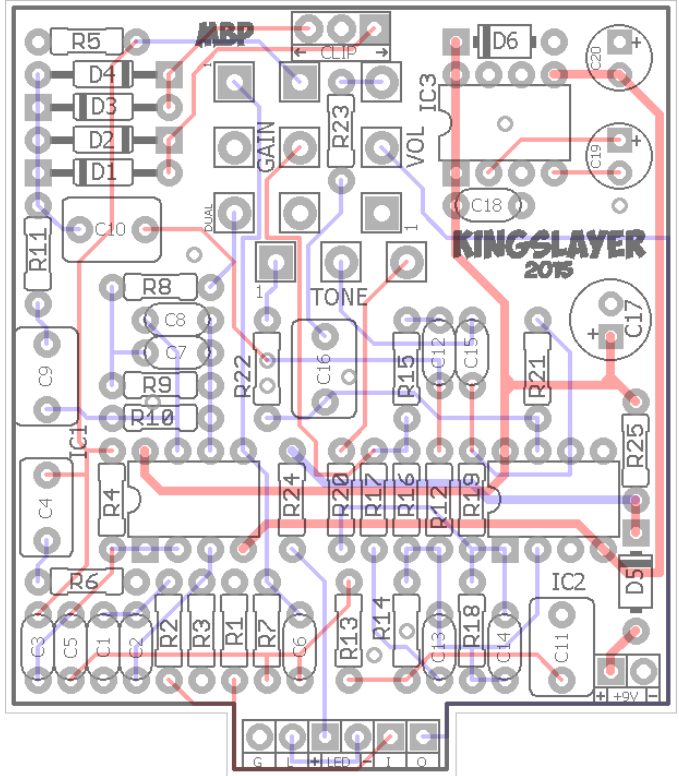
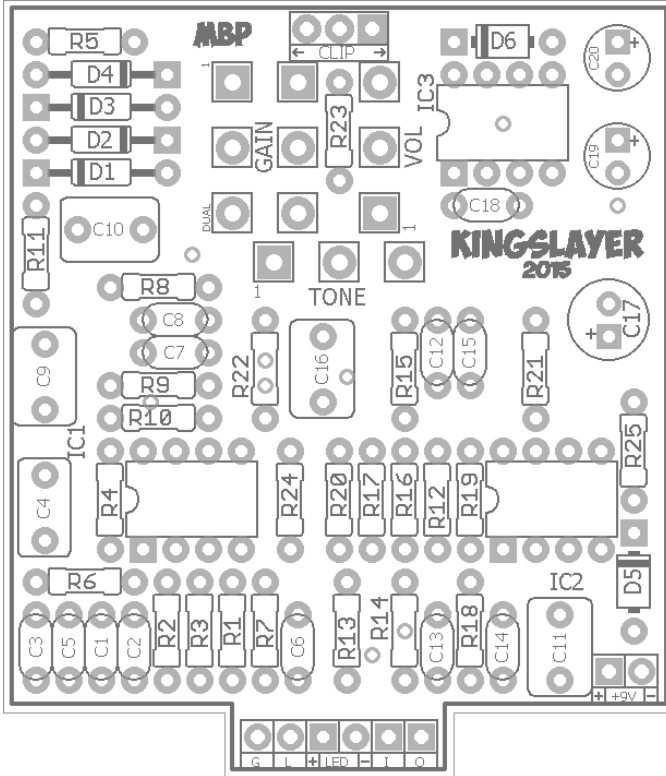

Terms of Use: You are free to use purchased **Kingslayer** circuit boards for both DIY and small commercial operations. You may not offer **Kingslayer** boards for resale or as part of a "kit" in a commercial fashion. Peer to peer re-sale is, of course, okay.

B.O.M.					
Resistors		Caps		Diodes	
R1	2M2	C1	220pF	D1, D2	your choice
R2	1k	C2	100n	D3, D4	1n34a
R3	1M	C3	68n	D5	1N5817
R4	5k1	C4	390n	D6	12v Zener
R5	1k5	C5	100n	IC's	
R6	1k	C6	68n	IC1	TL072
R7	10k	C7	82n	IC2	TL072
R8	2k	C8	390pF	IC3	TC1044SCPA
R9	15k	C9	1uF	Switch	
R10	422k	C10	1uF	CLIP	SPDT
R11	1k	C11	1uF	Pots	
R12	47k	C12	2n2	GAIN	100kB Dual
R13	1k5	C13	27n	TONE	10kB
R14	15k	C14	1n	VOL	10kA
R15	22k	C15	3n9		
R16	27k	C16	1uF		
R17	12k	C17	100uF		
R18	390k	C18	100n		
R19	100k	C19	10uF		
R20	1k8	C20	10uF		
R21	100k				
R22	4k7				
R23	470R				
R24	4k7				
R25	22R				

Shopping List

Value	QTY	Type	Rating
22R	1	Carbon / Metal Film	1/4W
470R	1	Carbon / Metal Film	1/4W
1k	3	Carbon / Metal Film	1/4W
1k5	2	Carbon / Metal Film	1/4W
1k8	1	Carbon / Metal Film	1/4W
2k	1	Carbon / Metal Film	1/4W
4k7	2	Carbon / Metal Film	1/4W
5k1	1	Carbon / Metal Film	1/4W
10k	1	Carbon / Metal Film	1/4W
12k	1	Carbon / Metal Film	1/4W
15k	2	Carbon / Metal Film	1/4W
22k	1	Carbon / Metal Film	1/4W
27k	1	Carbon / Metal Film	1/4W
47k	1	Carbon / Metal Film	1/4W
100k	2	Carbon / Metal Film	1/4W
390k	1	Carbon / Metal Film	1/4W
422k	1	Carbon / Metal Film	1/4W
1M	1	Carbon / Metal Film	1/4W
2M2	1	Carbon / Metal Film	1/4W
220pF	1	Ceramic / MLCC	25v min.
390pF	1	Ceramic / MLCC	25v min.
1n	1	Film	25v min.
2n2	1	Film	25v min.
3n9	1	Film	25v min.
27n	1	Film	25v min.
68n	2	Film	25v min.
82n	1	Film	25v min.
100n	3	Film	25v min.
390n	1	Film	25v min.
1uF	4	Film	25v min.
10uF	2	Electrolytic	25v min.
100uF	1	Electrolytic	25v min.
Diodes	2	1n914, 1N4001, LEDs	
1n34a	2	or, 1n270, DE9	
1N5817	1		
12v Zener	1		
TL072	2	or, your choice dual op-amp	
TC1044SCPA	1	see notes	
SPDT	1	On/On	
100kB Dual	1	PCB Right Angle	16mm
10kB	1	PCB Right Angle	16mm
10kA	1	PCB Right Angle	16mm

You can use any of the following Charge Pumps:
TC1044SCPA, ICL7660SCPA, MAX1044CPA

The 12v Zener is to protect over-spec voltage from damaging the charge pump. If you use the ICL or MAX versions, use a 9.1v Zener instead. BTW: The circuit will work without the Zener....so long as you never plug in the wrong power supply. If you do plug in the wrong supply without that Zener, you gonna not like it brah.

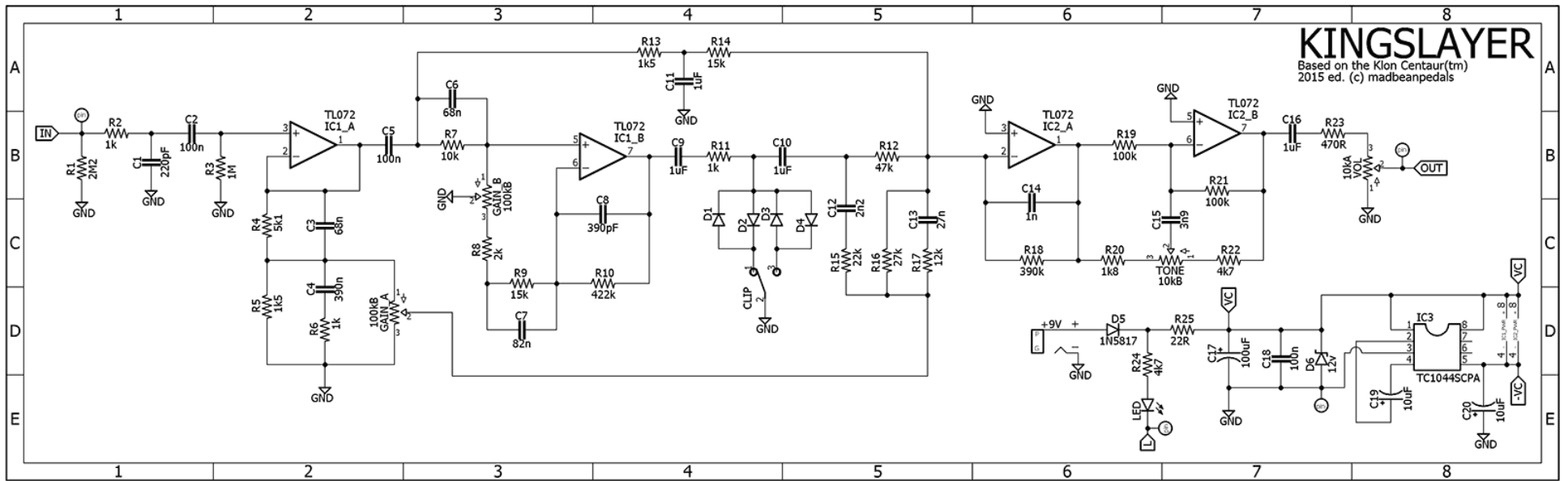

1590B Drill Guide

4.44" W x 6.45" H

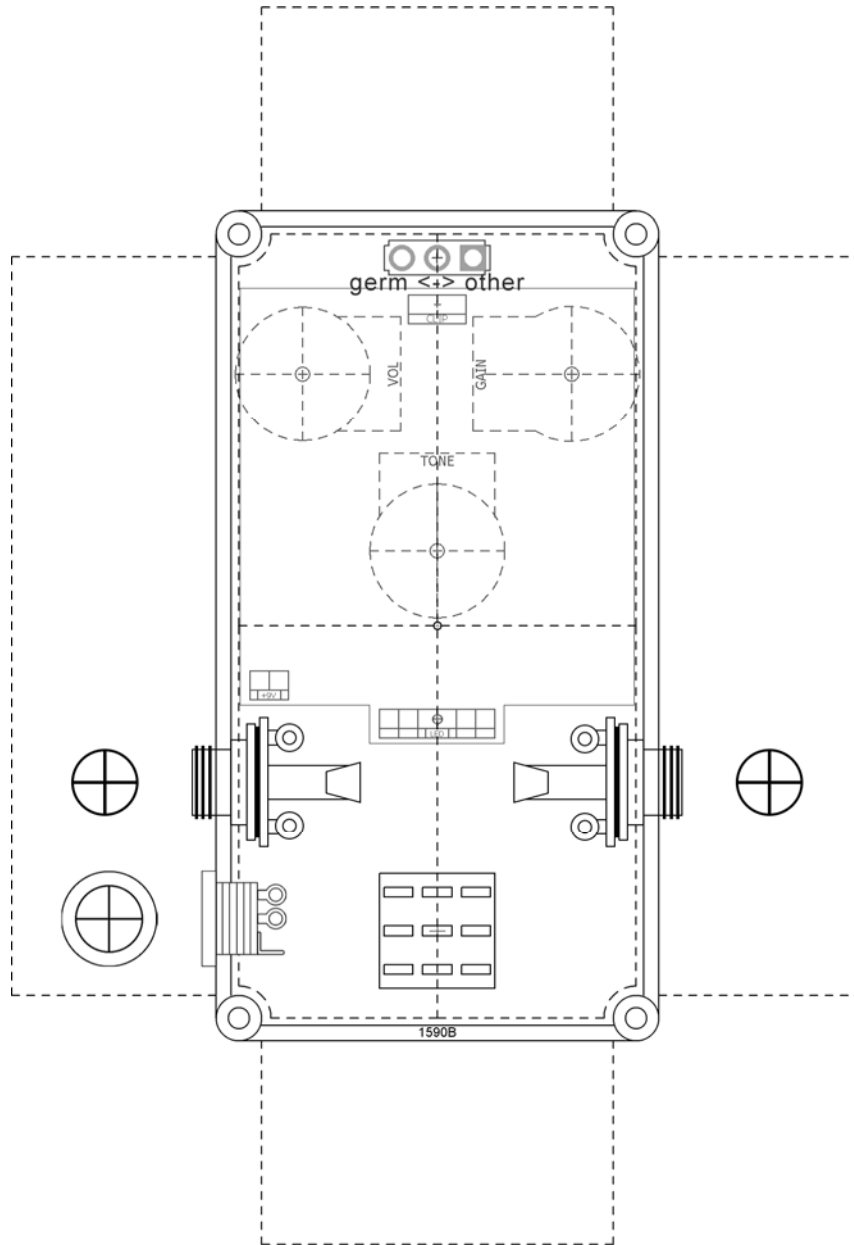

Wiring Guide

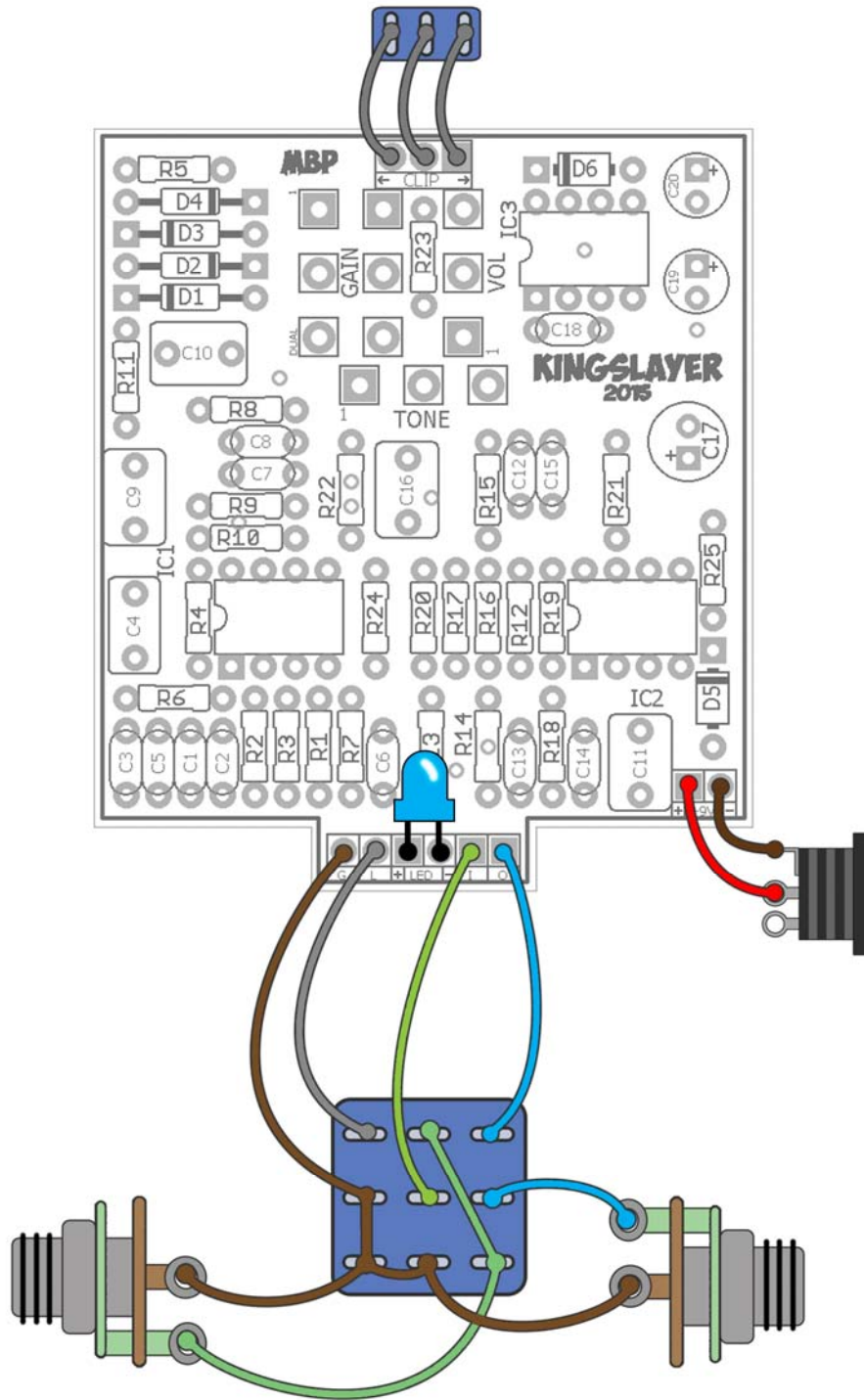

New for the 2015 edition

Layout – New, compact layout for the 1590B enclosure.

Circuit – Switch to dual op-amps, no buffer, and other minor tweaks.

What Is It?

The **Kingslayer** has been a staple project at madbeanpedals for a few years. It is a simplified version of the Klon Centaur with the stock power supply reduced to a bi-polar design. Doing so allows us to eliminate quite a few parts from the Klon™ design while keeping much of the higher voltage supply for which it is known.

Every iteration of the Kingslayer has offered a slightly different feature-set with tweaks here and there. The 2015 (final) edition is no exception. With the permanent discontinuation of the Sunking project, the Kingslayer has been changed again to bridge the gap between the two designs. The two biggest changes are the elimination of the buffered bypass and the switch from a quad op-amp to two dual amps like the original. The former is a consequence of the new, tighter 1590B layout. The latter is a stylistic choice to allow builder to experiment with a wider variety of op-amps. While I have listed TL072 as the default op-amps for IC1 and 2, you are by no means limited to that. You can experiment with any other dual op-amp that will operate at 18v. I also tried a 4580D in place of IC1, and liked it.

There are some other small circuit tweaks; 1) the input reduces the in-line resistor from 10k to 1k and adds an LP filter for RF attenuation, and 2) the tone control section has been changed back closer to the original “Centaur” (with the exception of C14 changing from 820pF to the more common 1n). Maybe my ears are wearing out, but the stock tone control is sounding better to me these days than it had previously. Or, perhaps this version with the dual op-amps just doesn’t sound as good with the darker tone control of the last Kingslayer version. Or, perhaps my using less and less of the AC-15 these days has reset my ears a bit. In any case, I’ve listed the values I preferred in my build of the 2015 edition, but you can always tweak them. The two parts to mess with are R20 and C15. Higher values in either spot will yield a darker tone control. In the previous version of the Kingslayer these were listed as 6k8 and 5n6 resp.

The Kingslayer is what I call a good “two up, one down” design. IOW, the best settings tend to happen when two controls are turned up and one down. For example, volume and gain up with tone floating between 10ock and 2ock. Or, volume and tone up with gain pretty far down (this is the boost setting). What it does not do is let you max everything out...unless you like lots of nasty feedback. This is a consequence of the design (true for every klon I’ve built...not just the Kingslayer and Sunking). You have lots of boost, gain and treble available, but pick two because all three just don’t work that well together. This is fine because there are still a lot of tonal varieties you can achieve, especially with the clipping switch (which allows you to use different clipping diodes). And, it also works very well as a hefty boost into a tube amp, which is precisely how most people use the Klon™. The distortion it produces can sound pretty good, but is not my favorite. I tend to like it best for rhythm playing and some lower gain lead playing. However, when used to goose/boost a second overdrive you can get some pretty stellar distorted lead tones. And, I just *know* you have some overdrives you can stack with this. Yuuuuup.

Controls

Vol – The output volume.

Tone – Active treble boost.

Gain – Dual-ganged pot which blends between the clean and dirty portions of the circuit design.

Clip – This switch allows you to choose either the stock diodes, or a second pair of your choosing (I use 3mm red diffused LEDs in my builds).

Voltages

IC1	TL072	IC2	TL072	IC3	TC1044
1	0	1	-12.7mV	1	8.83
2	1.2mV	2	-1.1mV	2	5.28
3	0	3	0	3	0
4	-8.36	4	-8.37	4	3.34
5	0	5	0	5	-8.37
6	0	6	0	6	4.24
7	1.3mV	7	12.1mV	7	5.45
8	8.83	8	8.83	8	8.83

Power Supply: One Spot measuring 9.40vDC

