

CHERRYBOMB

FX TYPE: FUZZ/OVERDRIVE

Based on the Coloursound® Overdriver™

© 2015 madbeanpedals

1.95" W x 1.95" H

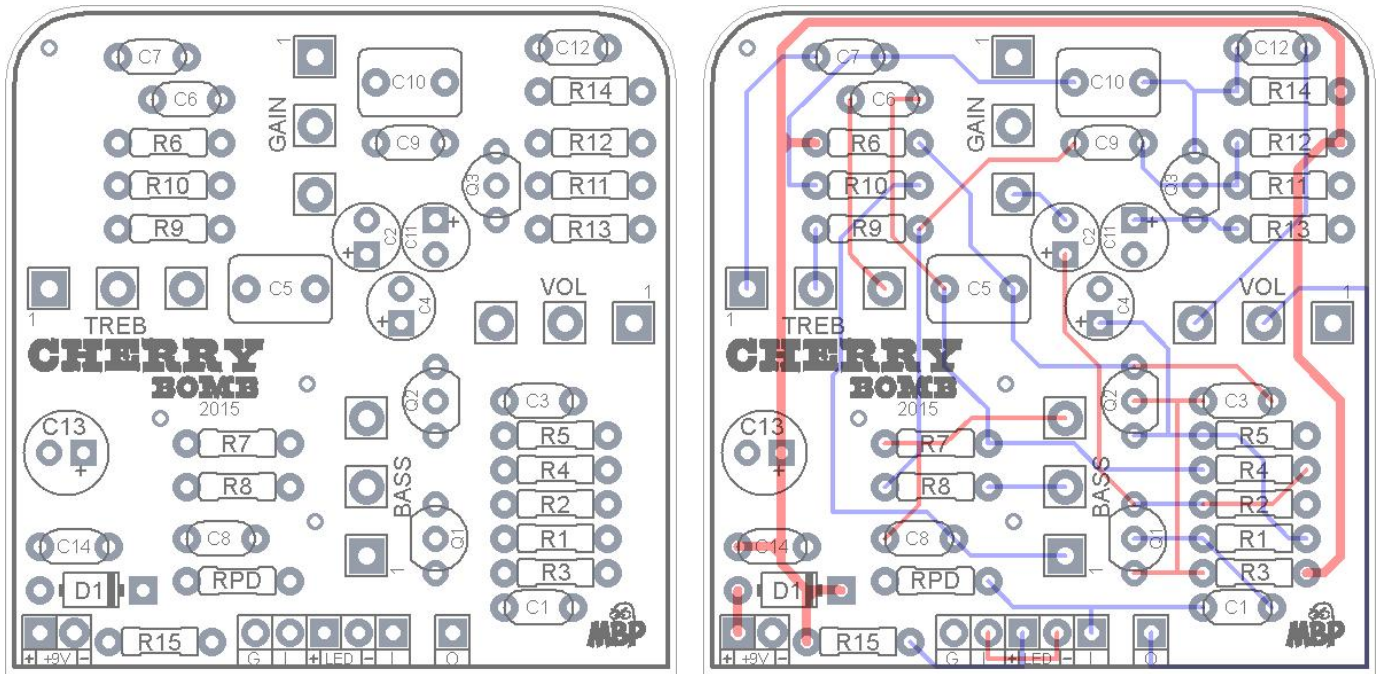

2015 Change-log

- Changed D1 to 1N5817
- Changed C5, C10 from 10uF electrolytic to 1uF film.
- Added optional pull-down resistor at input.

Terms of Use: You are free to use purchased **Cherrybomb** circuit boards for both DIY and small commercial operations. You may not offer **Cherrybomb** PCBs for resale or as part of a "kit" in a commercial fashion. Peer to peer re-sale is, of course, okay.

B.O.M.					
Resistors		Caps		Diodes	
R1	150k	C1	220n	D1	1N5817
R2	6k8	C2	22uF	Transistors	
R3	120k	C3	200pF	Q1 - Q3	see notes
R4	12k	C4	22uF	Pots	
R5	470R	C5	1uF	TREB	100kB
R6	1k8	C6	10n	BASS	100kB
R7	4k7	C7	10n	VOL	100kA
R8	39k	C8	100n	GAIN	1kC
R9	5k6	C9	100n		
R10	4k7	C10	1uF		
R11	33k	C11	22uF		
R12	150k	C12	220n		
R13	470R	C13	100uF		
R14	1k8	C14	100n		
R15	4k7				
RPD	1M				

Shopping List				
Value	QTY	Type	Rating	
470R	2	Metal / Carbon Film	1/4W	
1k8	2	Metal / Carbon Film	1/4W	
4k7	3	Metal / Carbon Film	1/4W	
5k6	1	Metal / Carbon Film	1/4W	
6k8	1	Metal / Carbon Film	1/4W	
12k	1	Metal / Carbon Film	1/4W	
33k	1	Metal / Carbon Film	1/4W	
39k	1	Metal / Carbon Film	1/4W	
120k	1	Metal / Carbon Film	1/4W	
150k	2	Metal / Carbon Film	1/4W	
1M	1	Metal / Carbon Film	1/4W	
200pF	1	Ceramic	16v min	
10n	2	Film	16v min	
100n	3	Film	16v min	
220n	2	Film	16v min	
1uF	2	Film	16v min	
22uF	3		16v min	
100uF	1	Electrolytic	16v min	
1N5817	1			
100kB	2	PCB Mount Short Pin	16mm	
100kA	1	PCB Mount Short Pin	16mm	
1kC	1	PCB Mount Short Pin	16mm	

See pg.5 for options on what transistors to use.

1590B Drill Guide

4.37" W x 6.46" H

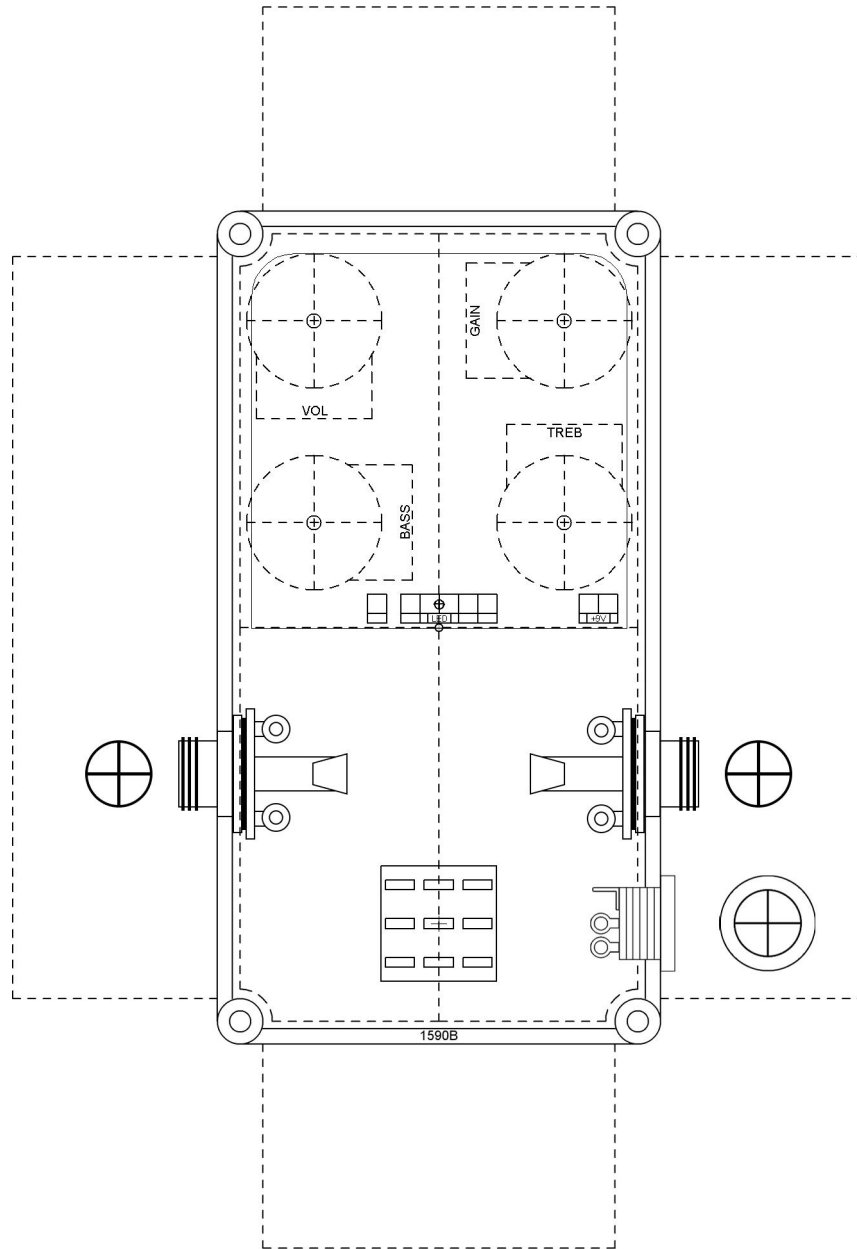

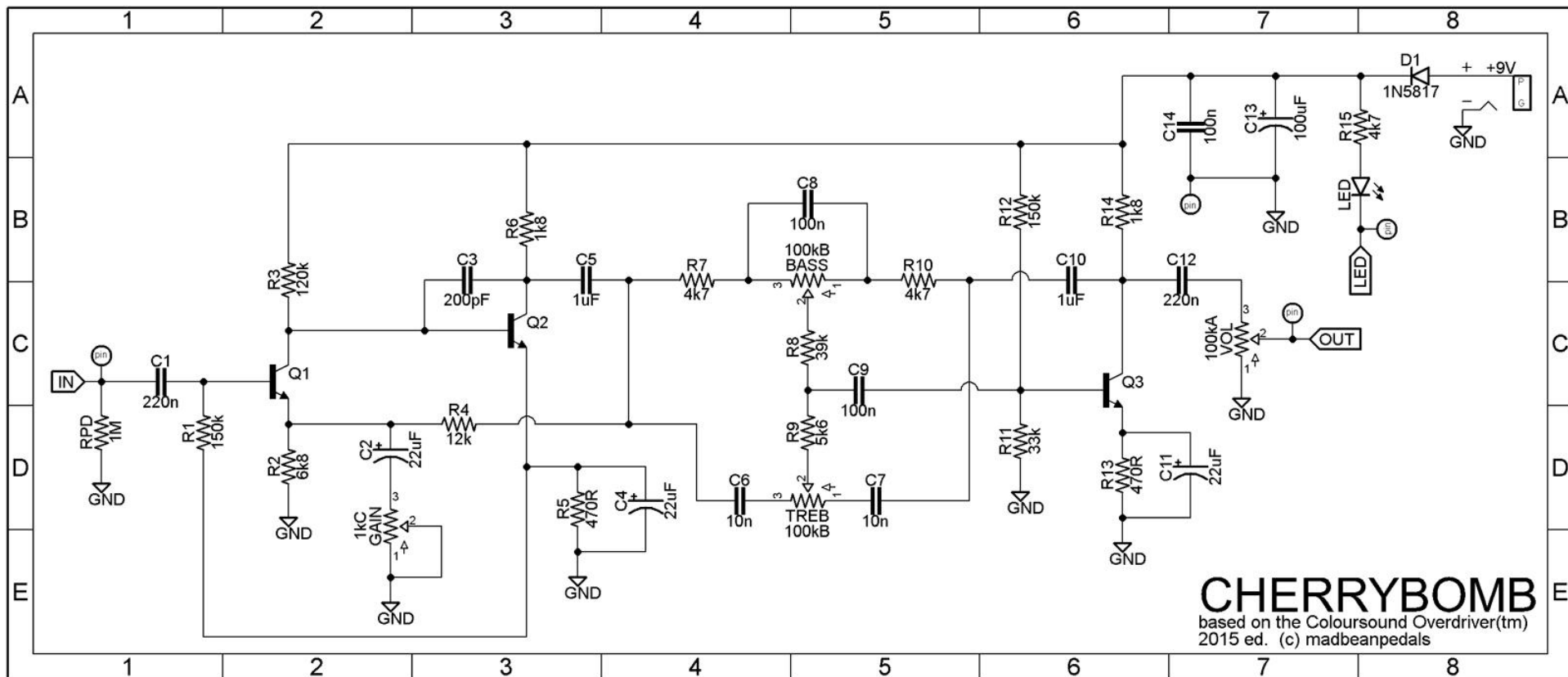

RPD is an optional pull-down resistor not used in the stock circuit.

Wiring Guide

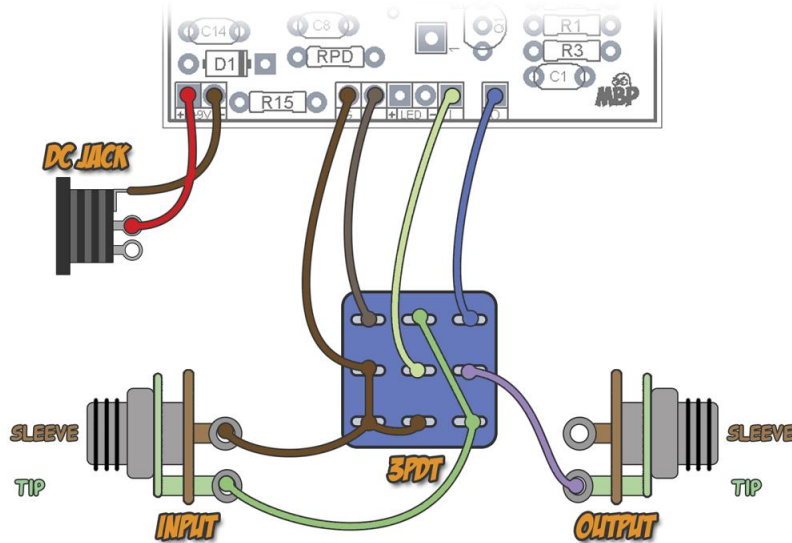

The **CherryBomb** is based on the Colorsound Overdriver™. Two transistors at the input stage provide the initial overdrive. This feeds into a passive Baxandall-type tone control which allows boost and cut of the **Bass** and **Treble** frequencies. A gain recovery stage rounds out the circuit just before the output.

The **CherryBomb** makes the following changes to the classic circuit:

- **C2** is listed as 22uF since it is more common than the original 25uF.
- The **Gain** pot is listed as 1kC (reverse audio) to prevent the extreme “bunching up” of the original 10kB.
- An output volume control has been added.

There seems to be a variety of opinions on which transistors were used in the CSOD. From the factory schematic it appears they were BC109

http://www.schematichaven.com/effects/colorsound_overdriver.pdf

However, two other schems list a mixture of BC169, BC184 and BC109

<http://fuzzcentral.ssguitar.com/schematics/overdriverschem.gif>

<http://www.freestompboxes.org/download/file.php?id=4125&mode=view>

BC109: <http://smallbear-electronics.mybigcommerce.com/bc10x-1/>

BC184L: <http://smallbear-electronics.mybigcommerce.com/transistor-bc184/>

BC169: <http://smallbear-electronics.mybigcommerce.com/transistor-bc169b-work-alike/>

Also, 2N3565: <http://smallbear-electronics.mybigcommerce.com/transistor-2n3565/>

There are likely a number of bi-polar transistors that will work but some might require re-biasing with the R3, R6 and R14 resistors. Be sure to mind the pin-outs of whichever transistors you use, as well. The CherryBomb transistors pins are the same as a 2N5088.

Voltages

Q1 - BC108 (140)	
Pin	vDC
C	1.66
B	0.91
E	0.359

Q2 - BC108 (140)	
Pin	vDC
C	5.43
B	1.66
E	1.02

Q2 - BC109 (190)	
Pin	vDC
C	6.29
B	1.42
E	0.788

I used a mix of BC108 and BC109 (hfe listed) based on what I had in stock. You can see from Q1 just how far squashed down the collector voltage is. So, one experimentation/tweaker point would be to play with the bias there and see what happens. I also tested 2n3565 in all three positions and the tonal result was almost identical...perhaps just slightly smoother fuzz.

Remember that the tab on the BC109 transistor indicates the emitter!

