

Shopping List				
Value	QTY	Type	Rating	Lead Spacing
1K	3	Metal / Carbon Film	1/8W	
3k3	2	Metal / Carbon Film	1/8W	
6k8	1	Metal / Carbon Film	1/8W	
10K	6	Metal / Carbon Film	1/8W	
12K	1	Metal / Carbon Film	1/8W	
14k3	4	Metal / Carbon Film	1/8W	
15K	1	Metal / Carbon Film	1/8W	
33K	2	Metal / Carbon Film	1/8W	
39K	2	Metal / Carbon Film	1/8W	
47K	1	Metal / Carbon Film	1/8W	
51K	1	Metal / Carbon Film	1/8W	
65k	1	Metal / Carbon Film	1/8W	
82K	2	Metal / Carbon Film	1/8W	
100K	1	Metal / Carbon Film	1/8W	
120K	1	Metal / Carbon Film	1/8W	
180K	1	Metal / Carbon Film	1/8W	
470K	1	Metal / Carbon Film	1/8W	
2M2	1	Metal / Carbon Film	1/8W	
10pF	1	MLCC	16v min.	2.5mm
47pF	1	MLCC	16v min.	2.5mm
220pF	1	MLCC	16v min.	2.5mm
1n	2	MLCC	16v min.	2.5mm
3n3	2	MLCC	16v min.	2.5mm
6n8	2	Film	16v min.	5mm
10n	1	MLCC	16v min.	2.5mm
15n	1	Film	16v min.	5mm
47n	1	Film	16v min.	5mm
100n	3	MLCC	16v min.	2.5mm
220n	2	Film	16v min.	5mm
1uF	1	Film	16v min.	5mm
10uF	1	Tantalum	16v min.	
10uF	4	Bi-Polar	16v min.	
22uF	2	Electrolytic	16v min.	
1n914	2			
2n5087	1			
2n5088	1			
CD4047	1			
LM358	1			
TLE2074	1			
MN3008	1			
SPDT	1	On/Off/On, Solder Lug		
100K	2	Bourns 3362p		
100kB	2	Plastic Shaft, PC Mount	9mm	
10kB	2	PC Mount, Right Angle	16mm	
500kC	1	PC Mount, Right Angle	16mm	

This list is for the audio board only. See the [Switching Board](#) doc for the parts needed for the switching system.

10pF: <http://www.mouser.com/ProductDetail/KEMET/C315C100J5G5TA/?qs=sGAEpiMZZMt3KoXD5rJ2Nw7wLkVkyXKYRhnIAHdAm6U%3d>

47pF: <http://www.mouser.com/ProductDetail/KEMET/C315C470J5G5TA/?qs=sGAEpiMZZMt3KoXD5rJ2NxtsVQ6hWgqD%2fZbwbX0nmE%3d>

220pF: <http://www.mouser.com/ProductDetail/KEMET/C320C221J2G5TA/?qs=sGAEpiMZZMt3KoXD5rJ2N%252bwgBl1a522xefKl%252bxFregl%3d>

1n: <http://www.mouser.com/ProductDetail/KEMET/C320C102J5G5TA/?qs=sGAEpiMZZMt3KoXD5rJ2NyCoF5j9nbtORIOlqJ9L0hY%3d>

3n3: <http://www.mouser.com/ProductDetail/KEMET/C320C332J5G5TA/?qs=sGAEpiMZZMt3KoXD5rJ2Nw7wLkVkyXKYwoyqc1D1nIA%3d>

10n: <http://www.mouser.com/ProductDetail/TDK/FG18C0G1H103JNT06/?qs=sGAEpiMZZMt3KoXD5rJ2N5U4Cys%2fUpTlqSWmruA3wbyX7d2yhizmuA%3d%3d>

100n: <http://www.mouser.com/Search/ProductDetail.aspx?R=C320C104K5R5TAvirtualkey64600000virtualkey80-C320C104K5R>

10uF BP: <http://www.mouser.com/Search/ProductDetail.aspx?R=ECE-A1EN100Uvirtualkey66720000virtualkey667-ECE-A1EN100U>

10uF Tantalum:

<http://www.mouser.com/ProductDetail/AVX/TAP106K016SCS/?qs=sGAEpiMZZMtZ1n0r9vR22d%252b8XmbM9QM8m263efWP9mg%3d>

LM358:

<http://www.mouser.com/ProductDetail/ON-Semiconductor-Fairchild/LM358N/?qs=sGAEpiMZZMtOXy69nW9rM%2fNIGKYEEm6ZXU8KMdhMoFY%3d>
or, <http://smallbear-electronics.mybigcommerce.com/ic-lm358/>

CD4047:

<http://www.mouser.com/ProductDetail/Texas-Instruments/CD4047BE/?qs=sGAEpiMZZMvlv4093HnhKZ8bAgIsdcd%2fHQD8%2fWa9R1o%3d>
or, <http://smallbear-electronics.mybigcommerce.com/ic-cd4047/>

TLE2074:

<http://www.mouser.com/ProductDetail/Texas-Instruments/TLE2074CN/?qs=sGAEpiMZZMtCHixnSjNA6CumnoLUEIgtkQTPuP%252bT7A%3d>

Bourns 100k (3362p):

<http://www.mouser.com/ProductDetail/Bourns/3362P-1-104LF/?qs=sGAEpiMZZMvygUB3GLcD7I39JMs%2f%2f%2fLOs09gVZSzi2c%3d>

9mm Plastic Shaft, PC Mount

<http://smallbear-electronics.mybigcommerce.com/alpha-single-gang-9mm-right-angle-pc-mount-w-knurled-plastic-shaft/>

16mm Right Angle, PC Mount: <http://smallbear-electronics.mybigcommerce.com/alpha-single-gang-16mm-right-angle-pc-mount/>

SPDT On/Off/On: <http://smallbear-electronics.mybigcommerce.com/spdt-short-lever-center-off/>

MN3008:

Unfortunately, this is up to you to source. ~~There is no single reliable vendor of the MN3008 that I know of.~~ At one time, smallbear had a bunch of MN3005 “fakes” that were actually MN3008 but those are long gone (in fact, I used one of them for my build). Your best course of action is to ask in the DIY community if someone has one for sale or knows a good source for them. Be very cautious about buying one from eBay – it’s tempting but fakes are very prevalent. You might get lucky...or you might waste a lot of time and money on non-functioning chips.

There is no substitute for the MN3008 in this build. You cannot use an MN3208 or one of the new Xvive MN3005.

Update Aug 2nd – Apparently there are some vendors with MN3008. These links were provided on the MBP forum:

<http://smallbear-electronics.mybigcommerce.com/ic-mn3008/>

http://uk-electronic.de/onlineshop/product_info.php?products_id=2911&osCsid=9f221cdcf9effa25ada3d403ca101ca7

http://www.retroamplis.com/epages/62070367.sf/es_ES/?ObjectPath=/Shops/62070367/Products/IC-MN3008

<https://www.banzaimusic.com/MN3008.html>

The Choral Reef does not require or include any specialized potentiometers.

Wiring

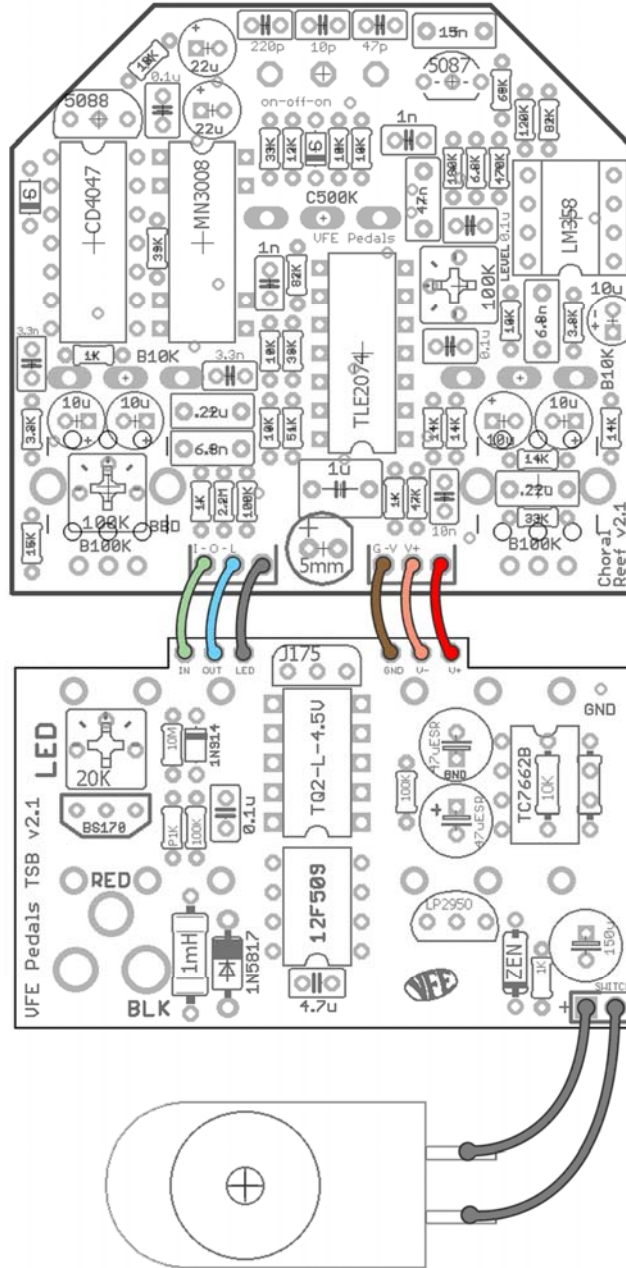

Be sure to read the Switching Board documentation before you build any of the VFE Projects:
http://www.madbeanpedals.com/projects/VFE/VFE_SwitchingBoard.pdf

The Drilling Guides are located here:
http://www.madbeanpedals.com/projects/VFE/VFE_DrillGuide.zip

Overview

The Choral Reef finds its roots in the EHX Small Clone™, but goes far beyond. Its design a bit unusual (although not unique) in that it utilizes an MN3008 instead of an MN3007 BBD. Peter explains his choice based on the available headroom of the MN3008 (it does have a slightly better S/N ratio than the MN3007). This choice also affords different clocking options to get faux-flanger as well as chorus type tones by switching through different timing caps. Rounding out the design is a simple buffered feedback path and delay control. All this adds up to a really unique and great sounding chorus with a ridiculous number of settings!

Controls

Descriptions from the VFE website: <http://www.vfepedals.com/choral-reef.html>

MIX: Blends between the wet, modulated signal and the dry signal. Crank it up to the max with shorter delay times for a vibrato effect, or set it around 9:00 with longer, spacier modulation settings for a dripping, watery chorus.

DEPTH: Sets the depth of the modulation. There's more than enough depth here to get you seasick, but turning this control all the way down removes the modulation for some unique doubling or uber-short delay effects.

SPEED: Sets the speed of the modulation, from rapid warble all the way down to super-slow, sweeping pitch-modulation.

FEED: At short delay times, this adds resonance and/or brightness to the modulation. At longer delay times, this increases the number of echo repeats.

WIDTH: Sets the delay time of the modulated signal. Shorter delay times yield flanger-esque tones, while the longest times can conjure quick slapback echos. NOTE: longer delay times = more clock noise

RANGE: Sets the range of the WIDTH control. The middle position has the shortest range, for flanger style tones. The right position is for the medium range, great for chorus. The left position is for the longest delay times, pushing the MN3008 to its absolute limits.

LEVEL: Sets the total output volume (internal trimmer). Note: I labeled this **VOL** on the schematic.

BBD: Sets the input bias of the MN3008 (internal trimmer).

Notes



On the audio board, do not populate the area labeled “omit cap”, This capacitor is not listed on the schematic or BOM.

Unique to the Choral Reef: populate the switching board with an 8k2 and 10k resistor as shown. Solder a 47uF cap exactly as shown (negative lead to the square pad). This cap/resistor combo provides a separate biasing rail to the audio circuit needed for operation. For reference, see the schematic on pg.9 of the [Switching Board](#) doc (area in blue).

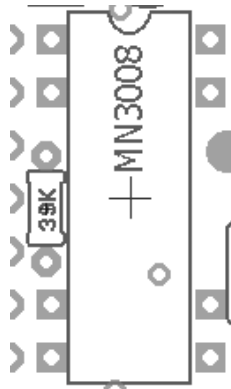

The audio board indicates a 39k resistor right under the MN3008. I suggest installing this resistor on the bottom of the PCB and using a socket for the MN3008.

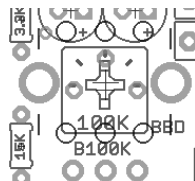

The trimmer on the lower left corner of the audio PCB is for biasing the Choral Reef. You can do this by ear. Set all knobs, trimmers and the switch to their middle positions. Connect a ¼” jack to the output jack on the switching board or audio probe the OUT pad on the audio board. Lightly turn the BBD trimmer until you get a clean chorusing sound (usually there will be a range on the trimmer where you hear it). You can set the Range switch to the right and vary the speed and depth knobs to check the extremes of the chorus effect – adjust the BBD trimmer as needed to get the best/cleanest chorusing. Note – you cannot damage the BBD by adjusting the BBD trimmer – adjust it as much as you need to get the best result.

Voltages

TLE2074		CD4047	
Pin	V	Pin	V
1	4.88	1	8.11
2	4.88	2	115-118mV
3	4.86	3	7.06
4	8.9	4	8.26
5	4.88	5	8.25
6	4.88	6	8.25
7	4.88	7	0
8	6.1	8	0
9	6.1	9	0
10	6.06	10	4.16
11	0	11	4.16
12	3.86	12	0
13	4.88	13	8.14
14	4.88	14	8.25

MN3008		LM358	
Pin	V	Pin	V
1	8.25	1	varies
2	4.16	2	4.02
6	6.09	3	4
7	6.09	4	0
8	0	5	varies
9	4.16	6	2.18
13	5.99	7	varies
14	0	8	8.9

5087		5088	
Pin	V	Pin	V
C	0	C	8.9
B	4.88	B	8.86
E	5.49	E	8.25

Some of these voltages will vary build to build depending on where the BBD trimmer is set.



Choral Reef
<http://www.vfepedals.com/>

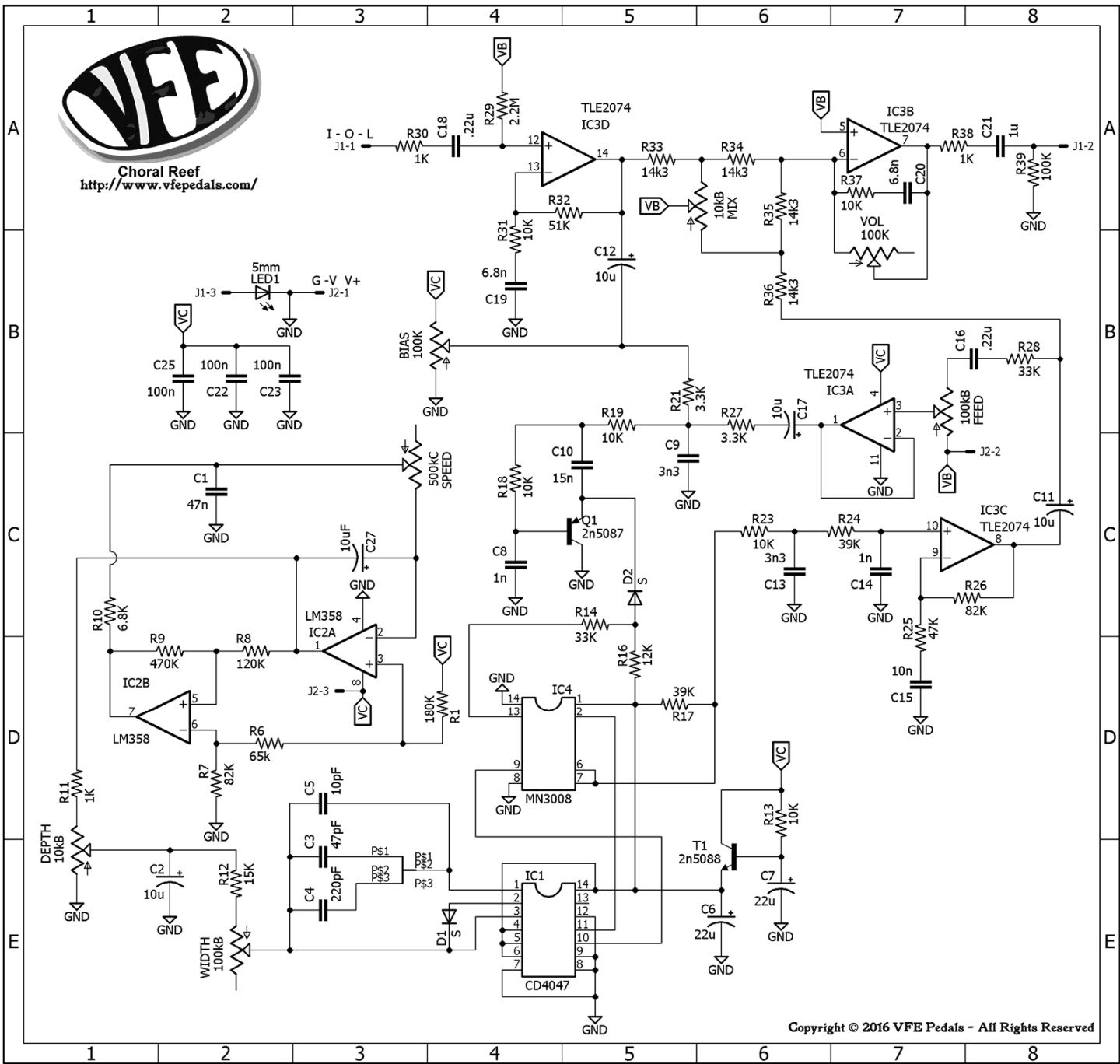

Copyright © 2016 VFE Pedals - All Rights Reserved