

PASTYFACE

FX TYPE: FUZZ

Based on the Fulltone® Soulbender™
2015 ed. © madbeanpedals

Download the previous version here:

<http://www.madbeanpedals.com/projects/Pastyface/docs/Pastyface.zip>

1.95" W x 1.875" H

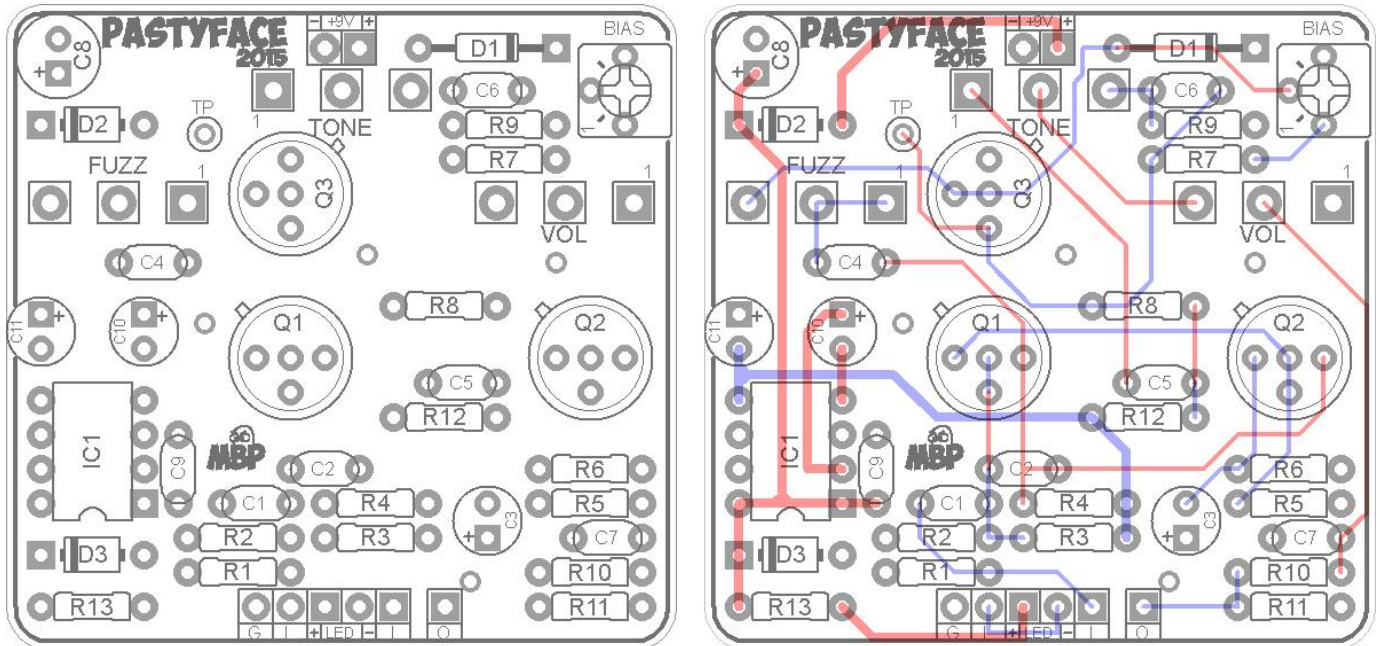

2015 Change-log

- Added voltage inverter
- New layout
- Changed R7 from 10k to 1k for wider bias range

Terms of Use: You are free to use purchased **Pastyface** circuit boards for both DIY and small commercial operations. You may not offer **Pastyface** PCBs for resale or as part of a "kit" in a commercial fashion. Peer to peer re-sale is, of course, okay.

B.O.M.					
Resistors		Caps		Diodes	
R1	1M	C1	100n	D1	1n270
R2	47k	C2	100pF	D2	1N5817
R3	220k	C3	10uF	D3	12v Zener
R4	10k	C4	220n	I.C.	
R5	10k	C5	100n	IC1	TC1044SCPA
R6	3k3	C6	15n	Transistors	
R7	1k	C7	150pF	Q1 - Q3	PNP
R8	18k	C8	100uF	Trimmer	
R9	10k	C9	100n	BIAS	500k
R10	47k	C10	10uF	Pots	
R11	1M	C11	10uF	TONE	100kB
R12	10k			FUZZ	100kB
R13	4k7			VOL	500kA

Shopping List				
Value	QTY	Type	Rating	
1k	1	Carbon/Metal or Carbon Comp	1/4W	
3k3	1	Carbon/Metal or Carbon Comp	1/4W	
4k7	1	Carbon/Metal or Carbon Comp	1/4W	
10k	4	Carbon/Metal or Carbon Comp	1/4W	
18k	1	Carbon/Metal or Carbon Comp	1/4W	
47k	2	Carbon/Metal or Carbon Comp	1/4W	
220k	1	Carbon/Metal or Carbon Comp	1/4W	
1M	2	Carbon/Metal or Carbon Comp	1/4W	
100pF	1	Ceramic	16v Min	
150pF	1	Ceramic	16v Min	
15n	1	Film	16v Min	
100n	3	Film	16v Min	
220n	1	Film	16v Min	
10uF	3	Electrolytic	16v Min	
100uF	1	Electrolytic	16v Min	
1n270	1	or, 1n34a or work-alike		
1N5817	1			
12v Zener	1			
TC1044SCPA	1	see notes		
PNP	3	see notes		
500k	1	Bourns 3362P		
100kB	2	PCB mount, Short Pin	16mm	
500kA	1	PCB mount, Short Pin	16mm	

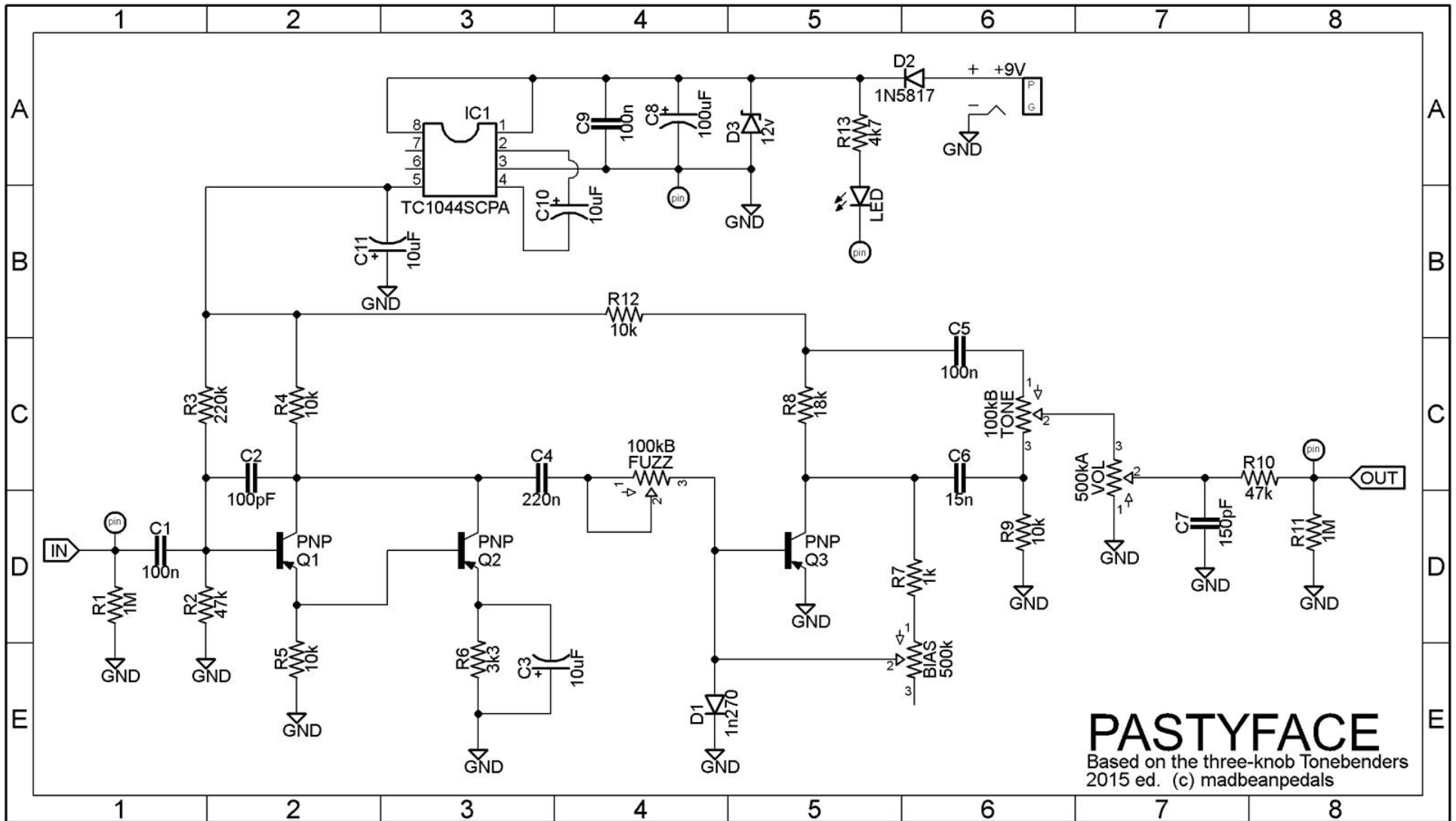

A

A

B

B

C

C

D

D

E

E

1

2

3

4

5

6

7

8

1

2

3

4

5

6

7

8

1590B Drill Guide

4.437" W x 6.46" H

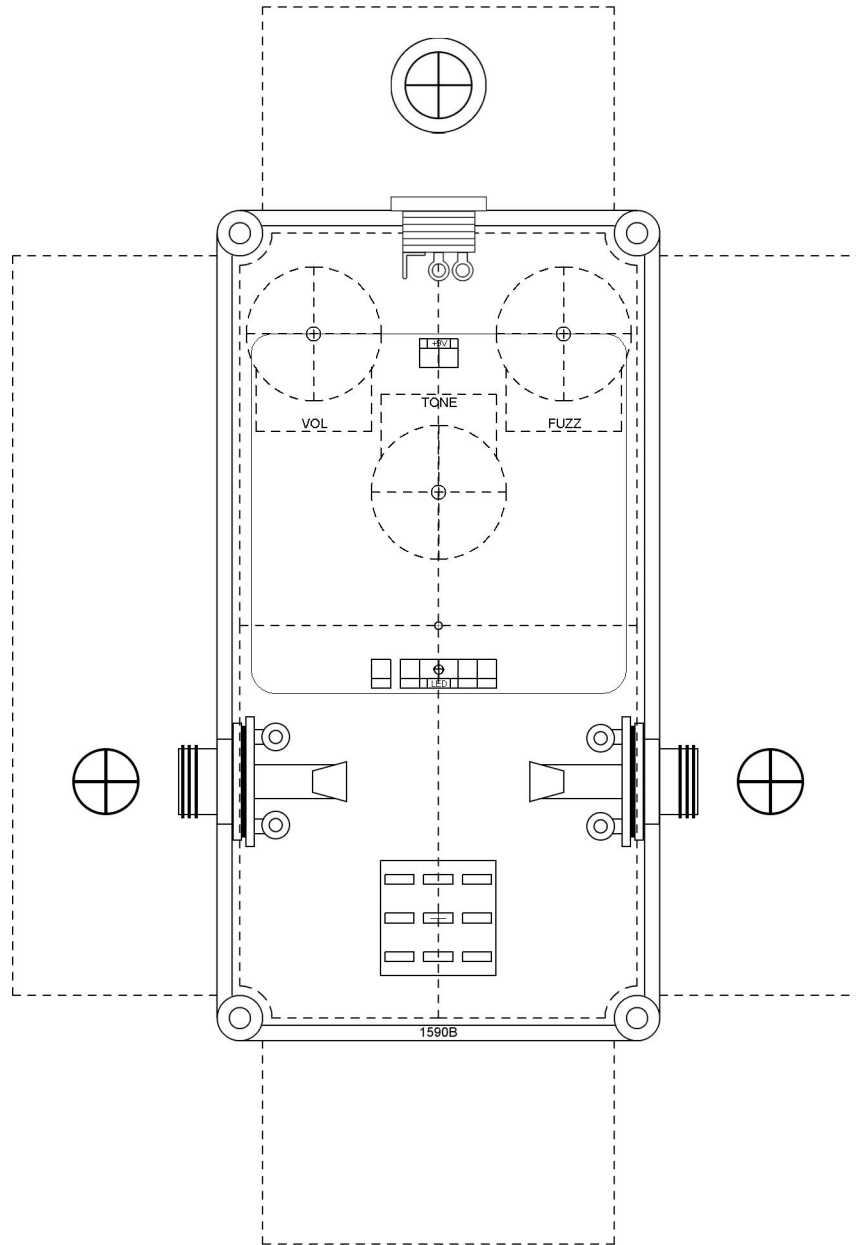

The LED can either mount directly to the PCB or be wired to another location.

Download the Photoshop file used to make this template here:

[http://www.madbeanpedals.com/projects/Pastyface/docs/Pastyface DRILL.zip](http://www.madbeanpedals.com/projects/Pastyface/docs/Pastyface_DRILL.zip)

Wiring Guide

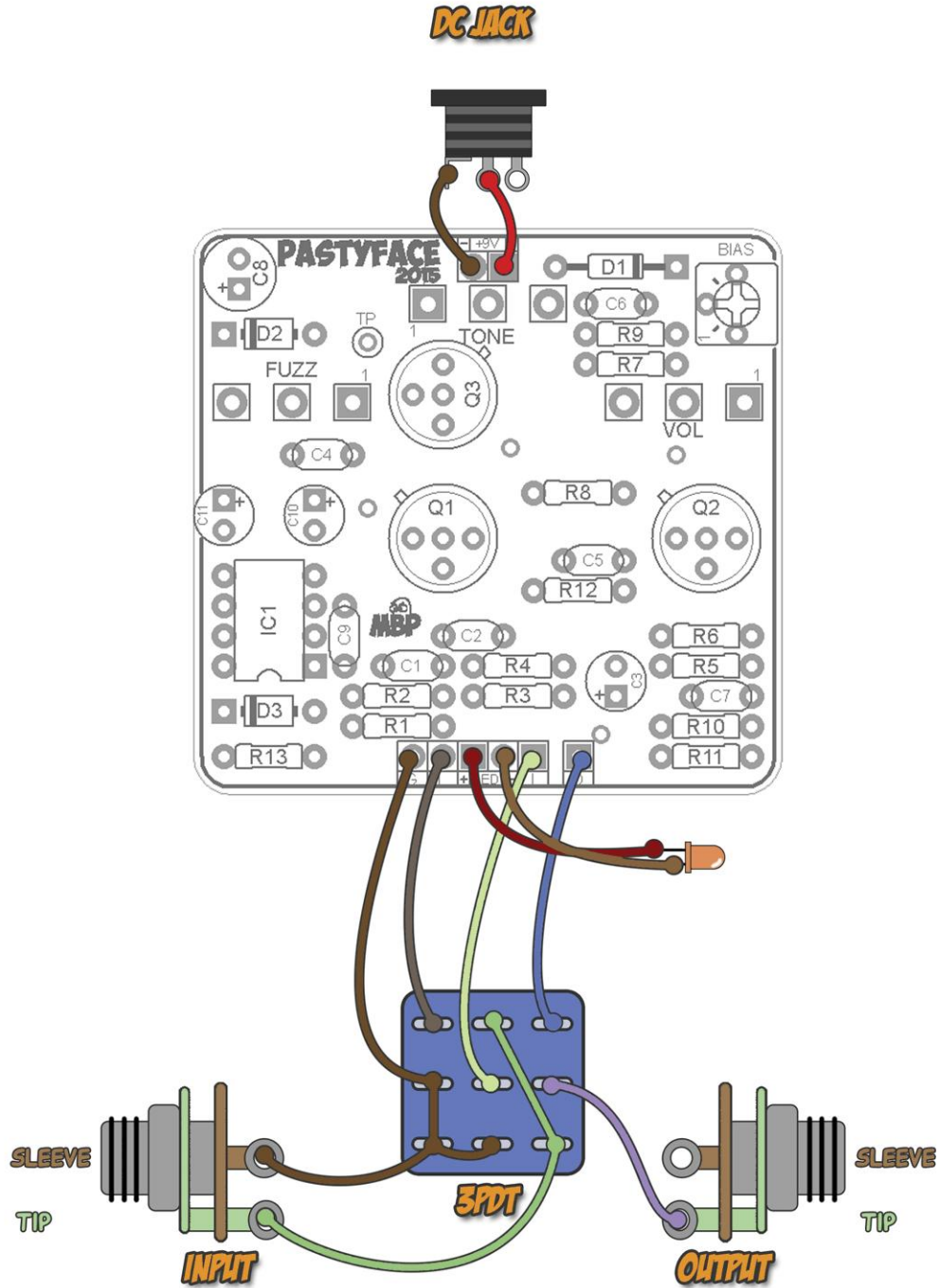

The 2015 edition of the **Pastyface** fuzz project goes back to its roots, namely a clone of the superior 3-knob Tonebender produced by Fulltone®, called the Soul Bender™. This version, IMO, trumps all other variations of the three knob 'benders (namely the Sola Sound, Park and Vox versions). It is an amazing fuzz circuit and one very worthy of any fuzz-nerds collection whether they are general consumers or DIY freaks like us. So, build it and rock on out.

Also, I should mention that the 2015 ed. focuses solely on the Soulbender version because I forgot to add in the extra two resistors needed to build the other variations.

However, this edition adds in a voltage inverter, meaning you no longer need to use a separate PCB to provide the -9v DC this fuzz uses. So, that's nice.

Controls

TONE: Mixes between two filters.

FUZZ: Total amount of fuzz.

VOL: The output level.

BIAS: This trimmer is for biasing Q3.

Notes

A matched Tonebender set of germanium transistors is recommended, but not required. You must use PNP germanium transistors for all three, however. Target gains for Q1-Q3 are 70-90, 80-100, and 100-120 resp. although this is not a precise requirement. Fuzzes can be very forgiving so long as your transistors are good (e.g. not too leaky). Matched sets can be purchased from Smallbear or similar suppliers. Smallbear usually supplies either a list or set of resistors that correctly bias the transistors in a standard Tonbender circuit. You can use these values if the provided test circuit is close to the Pastyface schematic. If not, stick with the BOM in this project.

The TC1044SCPA is recommended for the voltage inverter. You can also use the MAX1044CPA or the ICL7660SCPA. Make sure to pay attention to the CPA/SCPA designations. Only use the SCPA versions of the TC1044 or ICL7660. The MAX chip only comes with the CPA designation, but it actually has identical functionality to the other two (makes a lot sense there, doesn't it?)

Calibration

Think of this circuit as a negative ground effect like any other that you are used to building. We supply it +9v and then the charge pump inverts the power to -9v which supplies the transistors. You can use any standard negative ground power supply with the Pastyface, like the Voodoo Labs or the One Spot.

Populate the circuit with all parts wires and pots EXCEPT do not load your PNP transistors in...yet. Use your DMM to verify the following:

- 1) You have approximately +9v on pins 1 and 8 of IC1.
- 2) You have approximately -9v on pin5 of IC1.

Now disconnect the power. Load in your PNP transistors. If you have a matched set, mind that you load in the transistors in the correct positions, Q1, Q2 and Q3.

Reconnect the power. Using your DMM, attach the black lead to ground, and place the red lead on the TP pad located to the left of Q3. This measures the bias point on the collector of Q3. Adjust the Bias trimmer until you get about -4.5v. You can also tweak this by ear. The goal is to get the best fuzz sound out of Q3, so don't be too attached to numbers here.

That's it!

If you are unable to achieve good bias by adjusting the Bias trimmer, double check your resistor values to ensure they are correct, especially R4, R12, R18 and R7. If these are correct and you still cannot achieve proper bias you may have to alter the value of R8. If your TP reading is too low, make R8 smaller; say 10k or 12k. If it is too high, make R8 larger (almost never happens). If you get to this point, you might want to socket R8 so you do not have to solder/de-solder the same pads over and over. However, it is unlikely you will have to do any of these steps to begin with since the circuit is designed to get good bias from a range of transistor types.

Voltages

hFe - 86	
Q1	vDC
C	-3.84
B	-1.94
E	-1.44

hFe - 96	
Q1	vDC
C	-3.83
B	-1.44
E	-1.31

hFe - 103	
Q1	vDC
C	-4.8
B	0.112
E	0v

Q1 and Q2 are biased just a tad low in this setup. It is evidenced in the fact that the fuzz on this build was a little too squished and over-compressed. What I would do here is reduce R4 from 10k to maybe 8k2 or 7k5 to bring the collector voltages on Q1 and Q2 up a bit to something slightly over -4.2 / 4.3 vDC (technically UNDER since we are in negative voltage here). It sounds great even here, though. Rolling off the volume knob on the guitar cleans up almost completely so I might not mess with it at all. Alternatively I might audition another set of transistors if I can find them.

Keep In Mind!

PNP voltages can drift. After you bias Q3, wait a few minutes and re-check it. The D1 diode is meant to help with temperature stabilization but you may still find you bias voltage has shifted requiring another tweak of the trimmer. You want to bias this circuit according to how it behaves under use!

If you use the large transistor sockets like the drawings on the PCB, remember that the tab is the emitter. Make sure you put your particular transistors in the right way the first time (and all the time)!

There are two pads for the base pins (the two middle ones). These are for transistors whose pins are not arranged in a triangle fashion or if you are not using a socket.

